



Newton Fluid Technology Co., Ltd.

Newton Headquarters (Wenzhou)

Zhiyi road, Lingxia industrial zone, Wuniu, Wenzhou, Zhejiang, China.

Tel: 86-577-67978269

Fax: 86-577-67376711

E-mail: vmv@vmv-valve.com

Shanghai R & D Center

Jiading District, Shanghai
Building 12A, No. 1818 Chengbei Road
Tel: 86-18057752663
E-mail: vmv8@vmv-valve.com

Hangzhou R&D (Brand) Center

West Lake District, Hangzhou City, Zhejiang Province
Wenyi Road, Hangzhou Dianzi University, 4th Floor,
New Teaching Building
E-mail: vmv9@vmv-valve.com

Distributor

We provide overall Newton system and solution services from on-site investigation, project diagnosis, solution design, intelligent manufacturing of whole system products, implementation, and operation monitoring.

**Secure System Generates
Smart Energy Conservation**

VMV Newton Systems®

2022© Version and technical interpretation rights belong to Newton, Counterfeiting must be investigated!



Secure System Generates

Smart Energy Conservation



Newton Systems

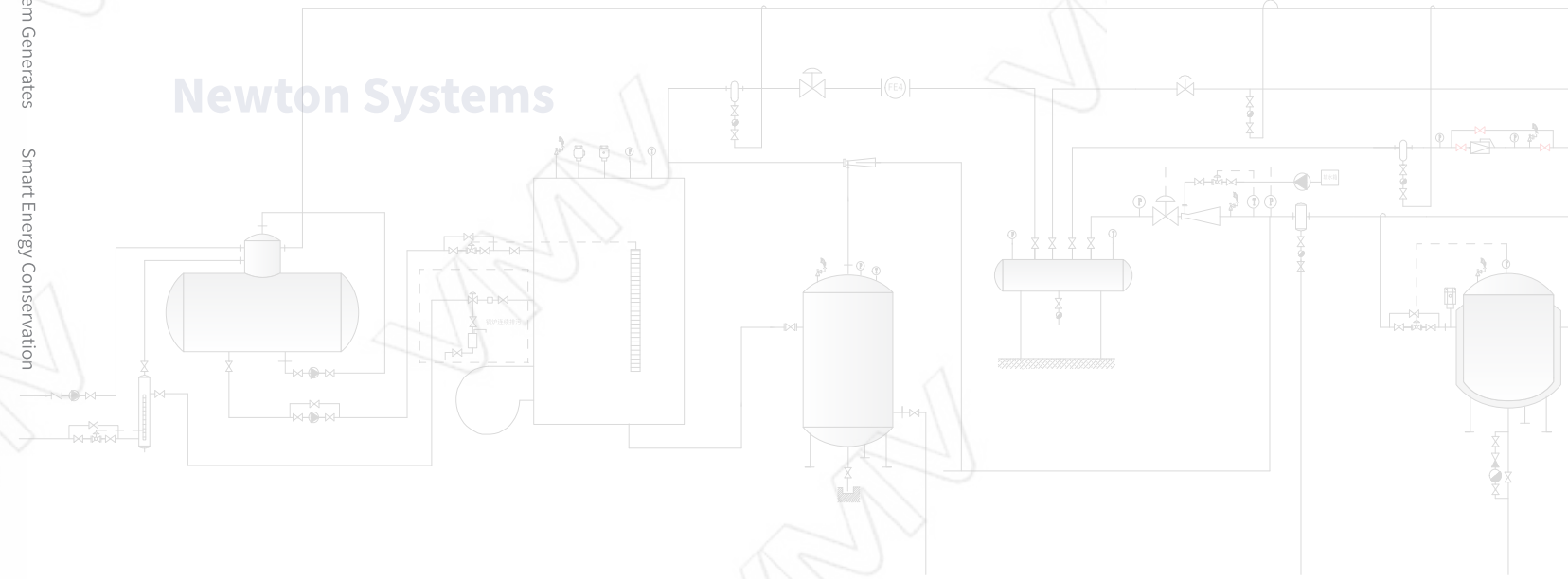

STEAM AND HEAT SMART ENERGY SAVING SYSTEM

Steam System Solutions

Steam Trap | Pump Trap Recovery System

Heat Tracing Manifolds / Bellows Globe Valve

Steam Pipe Accessories

2022© VMV®Newton Systems®All rights reserved

NEWTON STEAM AND HEAT SMART ENERGY SAVING SYSTEM

All-round and efficient automation

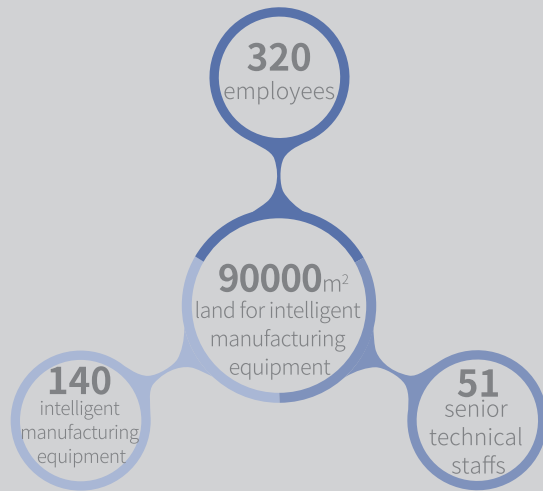

VMV Newton has advanced truss type 24 hour unmanned flexible manipulator machining center unit

- Department: Smart Manufacturing Product Workshop
- Highlights: Quality management construction, including intelligent cloud platform
- In the past few years, great progress has been made in terms of quality and efficiency. High precision and high requirements are always the first priority.
- The machine hand produces a product every two minutes, each accessory every minute.

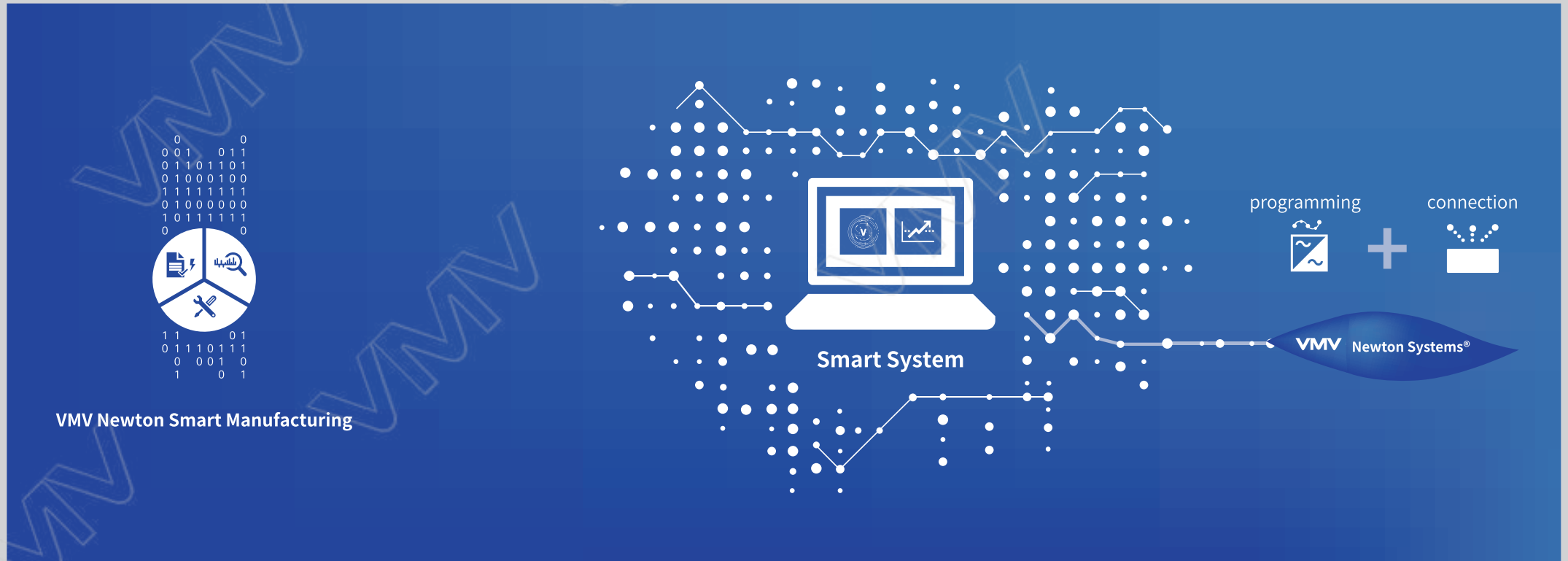

Precision smart manufacturing process



3D modeling design

Solidworks 3D modeling based on fluid mechanics, thermodynamics, and mechanical principles Pipe Flow Expert software fluid design check CAXA software technology and CNC programming perfect combination.

Manufacturing of key precision internals

High-precision internal parts use micro-enlargement projection to monitor the whole process of manufacturing and inspection, high-precision laser welding machine, to ensure seamless welding of internal parts of different materials Imported machine tools produce precision parts and ensure product performance.



Precision CNC Intelligent Manufacturing

5-axis CNC machining center Multi-station machining of CNC lathes using rotary hydraulic chucks, oneperson multi-machine operation, efficient manufacturing

CNC intelligent control cloud platform

Intelligent manufacturing cloud platform and ERP system height Realizing offline production and cloud management, including technical management, production management, quality management, financial management, performance management and other functional closed-loop intelligent manufacturing, the online work of all employees, and the digitalization of enterprise management.

Fully automatic 5-axis machining center, NB-IOT intelligent manufacturing cloud platform, and self-supplied supply chain system are all ensuring the energy saving effect and safe application of Newton's products

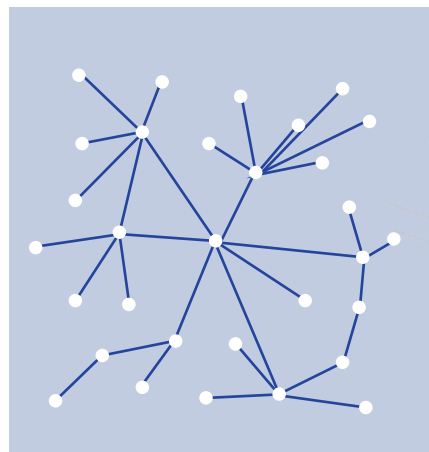

Newton's steam laboratory uses different pressures of steam to do type tests on each new product, Verify the pressure reduction ratio, closing performance and KV value of the pressure reducing valve; Verify the displacement curve, back pressure rate, and air leakage rate of steam traps, air traps, and pneumatic traps; Verify the displacement curve and fatigue times of pump traps; Verify the efficiency of jet pumps. We must check each steam product to leave the factory after passing the simulated action test.

Certificates



Patents



Test reports



Steam System Products



Model	Material	Max W. P. MPa	PN	Connection	Nominal Diameter			P25
					15	20	25	
SHT21T/W	A105	2.1	PN25	Threaded/Flange	●	●	●	
SHT21F	A105	2.1	PN25	Threaded/Flange	●	●	●	

Thermostatic (Bimetallic) Steam Trap
SHT21



Model	Material	Max W. P. MPa	PN	Connection	Nominal Diameter			P26
					15	20	25	
SHT21TVST/W	A105	2.1	PN25	Threaded/Flange	●	●	●	
SHT21TVSF	A105	2.1	PN25	Threaded/Flange	●	●	●	

Thermostatic (Bimetallic) Trap Station
SHT21TVS



Model	Material	Max W. P. MPa	PN	Connection	Nominal Diameter			P29
					15	20	25	
SKT16T-16	304	1.6	PN25	Threaded	●	●	●	
SKT16F-16	304	1.6	PN25	Flange	●	●	●	

Thermostatic (film box) Steam Trap
SKT16



Model	Material	Max W. P. MPa	PN	Connection	Nominal Diameter			P30
					15	20	25	
SHT1T	A105	2.1	PN25	Threaded	●	●	●	
SHT1C	A105	2.1	PN25	Ferrule	●	●	●	

Thermostatic (film box) Steam Trap
SHT1

Steam System Products

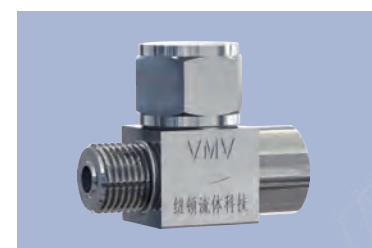

Model	Material	Max W. P. MPa	PN	Connection	Nominal Diameter	P33
STD01T-10	304	1.0	PN16	Threaded	1/4"	

Thermodynamic Steam Trap
STD01T



Model	Material	Max W. P. MPa	PN	Connection	Nominal Diameter			P34
					15	20	25	
STD16T/W	A105/SS	1.6	PN25	Threaded/Welded	●	●	●	
STD16F	A105/SS	1.6	PN25	Flange	●	●	●	

Thermodynamic Steam Trap
STD16



Model	Material	Max W. P. MPa	PN	Connection	Nominal Diameter			P35
					15	20	25	
STD42T/W-25	A105/SS	2.5	PN40	Threaded/Welded	●	●	●	
STD42F-25	A105/SS	2.5	PN40	Flange	●	●	●	

Thermodynamic (Disc) Steam Trap
STD42

STD42T/W-42	A105/15CrMo	4.2	PN63	Threaded/Welded	●	●	●	
STD42F-42	A105/15CrMo	4.2	PN63	Flange	●	●	●	

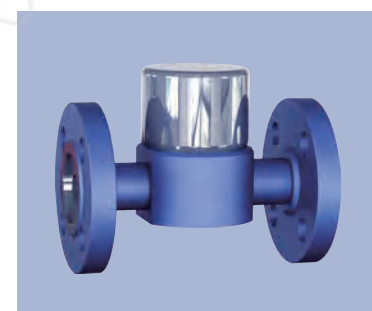

Model	Material	Max W. P. MPa	PN	Connection	Nominal Diameter			P36
					15	20	25	
STD80W	15CrMo	8.0	PN100	Welded	●	●	●	
STD80F	15CrMo	8.0	PN100	Flange	●	●	●	

Thermodynamic (Disc) Steam Trap
STD80

Steam System Products



Inverted Bucket Steam Trap

SBT10A / SBT20
SBT24 / SBT30

Model	Material	Max W. P. MPa	PN	Connection	Nominal Diameter					
					15	20	25	32	40	50
SBT10A/W-16	WCB/SS	1.6	PN25	Threaded/Welded	●	●	●			
SBT10AF-16	WCB/SS	1.6	PN25	Flange	●	●	●	●		
SBT20T/W-16	WCB/SS	1.6	PN25	Threaded/Welded	●	●	●	●		
SBT20F-16	WCB/SS	1.6	PN25	Flange	●	●	●	●	●	
SBT24T/W-32	WCB/SS	3.2	PN40	Threaded/Welded	●	●	●	●		
SBT24F-32	WCB/SS	3.2	PN40	Flange	●	●	●	●	●	
SBT30T/W-16	WCB/SS	1.6	PN25	Threaded/Welded		●	●	●		
SBT30F-16	WCB/SS	1.6	PN25	Flange		●	●	●	●	

P39



Inverted Bucket Steam Trap

SBT11A

Model	Material	Max W. P. MPa	PN	Connection	Nominal Diameter		
					15	20	25
SBT11AT/W-17	CF8/SS	1.7	PN25	Threaded/Welded	●	●	●
SBT11AF-17	CF8/SS	1.7	PN25	Flange	●	●	●

P43



Inverted Bucket Steam Trap

SBT11TVS

Model	Material	Max W. P. MPa	PN	Connection	Nominal Diameter		
					15	20	25
SBT11TVS	CF8/SS	1.7	PN25	Threaded/Welded	●	●	●
SBT11TVS	CF8/SS	1.7	PN25	Flange	●	●	●

P44



Pilot Inverted Bucket Steam Trap

SBT40 / SBT50
SBT53 / SBT60
SBT63

Model	Material	Max W. P. MPa	PN	Connection	Nominal Diameter					
					25	32	40	50	65	80
SBT40T/W-16	WCB/SS	1.6	PN25	Threaded/Welded	●	●				
SBT40F-16	WCB/SS	1.6	PN25	Flange	●	●	●	●		
SBT50F-16	WCB/SS	1.6	PN25	Flange	●	●	●	●	●	
SBT53F-32	WCB/SS	3.2	PN40	Flange	●	●	●	●	●	●
SBT60F-16	WCB/SS	1.6	PN25	Flange	●	●	●	●	●	●
SBT63F-32	WCB/SS	3.2	PN40	Flange	●	●	●	●	●	●

P47



Lever Ball Float Steam Trap

SFT10

Model	Material	Max W. P. MPa	PN	Connection	Nominal Diameter		
					15	20	25
SFT10T/W-16	WCB/SS	1.6	PN25	Threaded/Welded	●	●	●
SFT10F-16	WCB/SS	1.6	PN25	Flange	●	●	●

P55



Lever Ball Float Steam Trap

SFT10A

Model	Material	Max W. P. MPa	PN	Connection	Nominal Diameter		
					15	20	25
SFT10AT/W-16	WCB/SS	1.6	PN25	Threaded/Welded	●	●	●
SFT10AF-16	WCB/SS	1.6	PN25	Flange	●	●	●

P56

Steam System Products



Lever Ball Float Steam Trap

SFT20A / SFT23A
SFT30A / SFT40A

Model	Material	Max W. P. MPa	PN	Connection	Nominal Diameter					
					15	20	25	32	40	50
SFT20AT/W-16	WCB/SS	1.6	PN25	Threaded/Welded	●	●	●			
SFT20AF-16	WCB/SS	1.6	PN25	Flange	●	●	●	●	●	
SFT23AT/W-32	WCB/SS	3.2	PN40	Threaded/Welded	●	●	●			
SFT23AF-32	WCB/SS	3.2	PN40	Flange	●	●	●	●	●	
SFT30AT/W-16	WCB/SS	1.6	PN25	Threaded/Welded	●	●	●			
SFT30AF-16	WCB/SS	1.6	PN25	Flange	●	●	●	●	●	
SFT40AF-16	WCB/SS	1.6	PN25	Flange	●	●	●	●	●	

P57

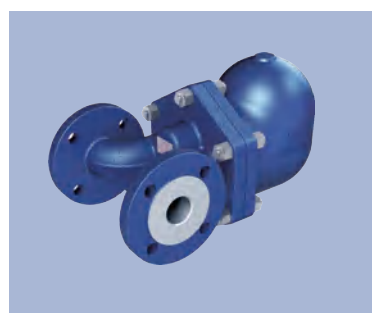

Lever Ball Float Steam Trap

SFT50 / SFT53

Model	Material	Max W. P. MPa	PN	Connection	Nominal Diameter			
					32	40	50	65
SFT50F-16	WCB/SS	1.6	PN40	Flange	●	●	●	●
SFT50F-32	WCB/SS	3.2	PN40	Flange	●	●	●	●

P60



Lever Ball Float Steam Trap

SFT60

Model	Material	Max W. P. MPa	PN	Connection	Nominal Diameter			
					40	50	60	80
SFT60F-20	WCB/SS	2.0	PN40	Flange	●	●	●	●
SFT60F-32	WCB/SS	3.2	PN40	Flange	●	●	●	●

P61



Lever Ball Float Steam Trap

SFT66

Model	Material	Max W. P. MPa	PN	Connection	Nominal Diameter			
					40	50	60	80
SFT66F-45	WCB/SS	4.5	PN100	Flange	●	●	●	●
SFT66F-65	WC6/SS	6.5	PN100	Flange	●	●	●	●

P62



Lever Ball Float Steam Trap

SFT70

Model	Material	Max W. P. MPa	PN	Connection	Nominal Diameter		
					65	80	100
SFT70F-20	WCB/SS	2.0	PN40	Flange	●	●	●
SFT70F-32	WCB/SS	3.2	PN40	Flange	●	●	●

P63



Lever Ball Float Steam Trap

SFT80/80A/80B

Model	Material	Max W. P. MPa	PN	Connection	Nominal Diameter		
					65	80	100
SFT80	WCB/SS	3.2	PN40	Flange	●	●	●
SFT80A	WCB/SS	3.2	PN40	Flange	●	●	●
SFT80B	WCB/SS	3.2	PN40	Flange	●	●	●

P64



Automatic Level Control Device for Vapour-Liquid Two-Phase Flow Trap
QYL

Model	Material	Max W. P. MPa	PN	Connection	Nominal Diameter		
					80	200
QYL-16	A105/SS	1.6	PN16	Flange	●	●	●
QYL-25	A105/SS	2.5	PN25	Flange	●	●	●
QYL-40	A105/SS	4	PN40	Flange	●	●	●
QYL-63	A105/SS	6.3	PN63	Flange	●	●	●

P66

Steam System Products

Steam System Products



Lever Ball Float Air Trap

AFT20 / AFT30
AFT40

Model	Material	Max W. P. MPa	PN	Connection	Nominal Diameter				
					15	20	25	32	40
AFT20T/W-16	WCB/SS	1.6	PN25	Threaded/Welded	●	●	●		
AFT20F-16	WCB/SS	1.6	PN25	Flange		●	●	●	●
AFT30T/W-16	WCB/SS	1.6	PN25	Threaded/Welded			●	●	
AFT30F-16	WCB/SS	1.6	PN25	Flange			●	●	●
AFT40F-16	WCB/SS	1.6	PN25	Flange			●	●	●

P69



Pump Trap

PT20

Model	Material	Max W. P. MPa	PN	Connection	Nominal Diameter	
					50	80
PT20	WCB/SS	1.37	PN16	Flange	●	●

P73



Pump Trap

PT10

Model	Material	Max W. P. MPa	PN	Connection	Nominal Diameter		
					25	32	40
PT10	WCB/SS	1.37	PN16	Flange	●	●	●

P77



System Device of Single Pump Trap

SPT20S



System Device of Double Pump Trap

SPT20D



System Device of Three pump Trap

SPT20T

Model	Material	Max W. P. MPa	PN	Connection	Nominal Diameter		
					50	80	100
SPT20S	CS/SS	1.37	PN16	Flange	●	●	
SPT20D	CS/SS	1.37	PN16	Flange		●	
SPT20T	CS/SS	1.37	PN16	Flange			●

P79



Bellows Stainless Steel Steam Distribution Manifolds

BSPM03 / BCRM03

Name	Model	Material	Max W. P. MPa	Pressure	Connection	Nominal Diameter	
						25	40
Bellows Stainless Steel Steam Distribution Tube Manifolds	BSPM03	CF8/SS	5	PN40 CL300	RF/RC / LOC	●	●
Bellows Stainless Steel Condensate Collection Manifolds	BCPM03	CF8/SS	5	PN40 CL300	RF/RC/ LOC	●	●

P87



Bellows Forged Steel Steam Distribution Manifolds

BSPM02 / BCRM02

Name	Model	Material	Max W. P. MPa	Pressure	Connection	Nominal Diameter	
						25	40
Bellows Forged Steel Steam Distribution Manifolds	BSPM02	A105/SS	5	PN40 CL300	RF/RC / LOC	●	●
Bellows Forged Steel Condensate Collection Manifolds	BCPM02	A105/SS	5	PN40 CL300	RF/RC/ LOC	●	●

P92

Steam System Products



**Control Valve/
Bellows Control Valve/
Three Way Control Valve**

V8000 Series/V6000 Series

Model	Material	Max W. P. MPa	PN	Connection	Nominal Diameter		
					25	...	300
V8000	WCB/SS	1.6	PN16	Flange	●	●	●
V8000	WCB/SS	2.5	PN25	Flange	●	●	●
V8000	WCB/SS	4	PN40	Flange	●	●	●
V6000	WCB/SS	1.6	PN16	Flange	●	●	●
V6000	WCB/SS	2.5	PN25	Flange	●	●	●
V6000	WCB/SS	4	PN40	Flange	●	●	●

P99



Bellows Sealed Globe Valve

Name	Model	Material	Max W. Pressure P. MPa	Connection	Nominal Diameter			
						15	20	...
Bellows Sealed Globe Valve	WJ41H-16C	WCB/304	1.6	PN16 CL150	RF	●	●	●
Bellows Sealed Globe Valve	WJ41H-25C	WCB/304	2.5	PN25 CL150	RF	●	●	●
Bellows Sealed Globe Valve	WJ41H-40C	WCB/304	4.0	PN40 CL300	RF	●	●	●

P109



Bellows Sealed Gate Valve

Name	Model	Material	Max W. Pressure P. MPa	Connection	Nominal Diameter			
						15	20	...
Bellows Sealed Gate Valve	WZ41H-16C	WCB/SS	1.6	PN16 CL150	RF	●	●	●
Bellows Sealed Gate Valve	WZ41H-25C	WCB/SS	2.5	PN25 CL150	RF	●	●	●
Bellows Sealed Gate Valve	WZ41H-40C	WCB/SS	4.0	PN40 CL300	RF	●	●	●

P111

Steam System Products



Vacuum Breaker
VB21



Silencer
DF3

Model	Material	Max W. P. MPa	PN	Connection	Nominal Diameter		
					15	20	25
VB21	304	2.1	PN25	RC	●	●	●
DF3	304	4	PN40	RC	●	●	●

P113

P115



Mixer
IM40M



Single Mixer
IN

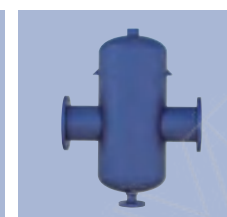

Water Separator
AS7



Wafer Check Valve
Z71H-25P



Y Strainer

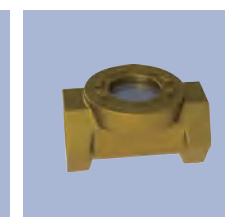

Sight Glass

Model	Material	Max W. P. MPa	PN	Connection	Nominal Diameter												
					15	20	25	32	40	50	65	80	100	125	150	200	
IM40M	304	4	PN40	RC					●								
IN	304	2.5	PN15	RC	●	●	●	●	●	●	●	●	●	●	●	●	●
AS7	20#	1.6	PN16	RC	●	●	●	●	●	●	●	●	●	●			
ZM71H-16P	CF8	1.6	PN16	RC	●	●	●	●	●	●	●	●	●	●	●	●	●
Y-STRAINER	WCB	4	PN40	RC	●	●	●										
Sight Glass	Brass	0.5	PN5														

P116

P117

P118

P119

P120

P121

Customized Products



Steam Ejector



Condensate Flash Recovery System



Condensate Flash System

P122

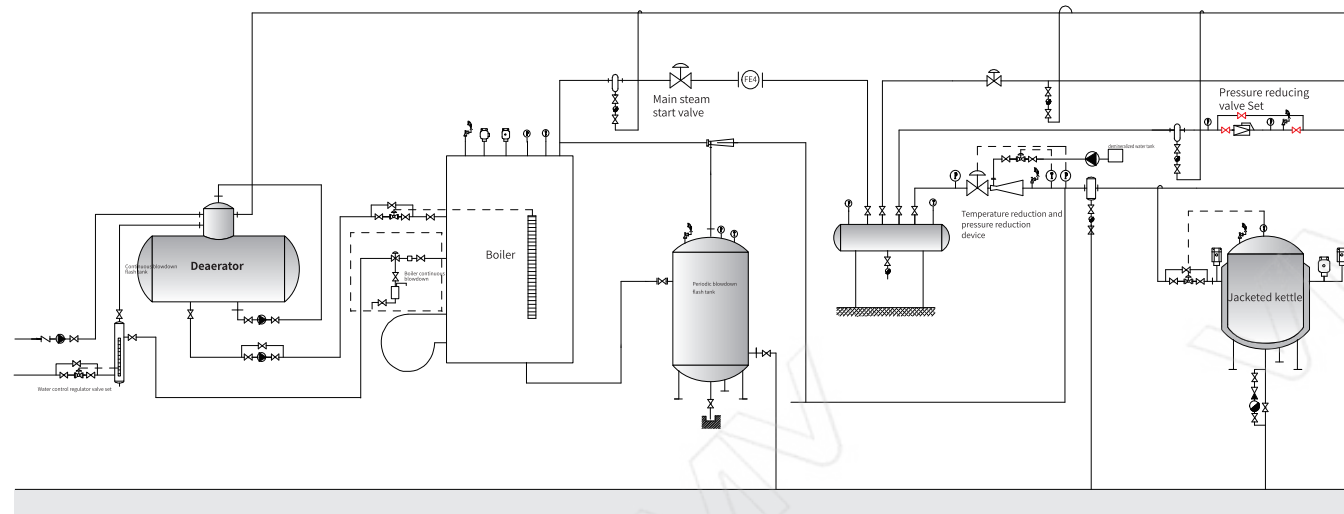

K—Knowledge Provide professional knowledge of steam. Including steam properties, selection of pressure reducing valve, solutions of temperature & pressure reduction device, control system of pressure flow, process piping of steam pipeline, selection of trap, recovery of condensate, solutions of steam recovery etc.

C—Consulting System consultation diagnosis and design process plan. With the assistance of the user, have a detailed understanding of the production equipment, through on-site photography, recording detailed data, searching for process flow charts, and in-depth understanding of the current status of steam system piping, steam and condensate use, and finding out the existing problems of the system, according to the industrial energy-saving standard workbook compiled by VMV proposes optimization plans and formulates process plans.

P—Product Provide quality and reliable products.

Bellows sealed globe valve with safe, reliable and switch flexible.

Steam trap with high efficiency, energy saving and long life, pump traps for heat recovery, and condensate recovery devices.

Pressure reducing valve group and temperature & pressure reducing device with safe and reliable.

Steam distribution bundles and condensate manifold bundles with space and cost saving, easy to maintain.

Suitable for high-performance exhaust valves, air traps, drain valves, vacuum breakers, check valves, filters, silencer, mixers and other piping accessories under various working conditions.

S—Service Provide timely pre-sale and after-sale service. Establish a complete online and offline communication mechanism, so that every user can enjoy the technical services and technical support provided by VMV, and realize the concept of serving users.

Professional Terms

Saturated steam: refers to pure steam corresponding to the boiling point temperature of water under a certain pressure.

Superheated Steam: Steam with a temperature higher than saturated steam.

Absolute pressure and gauge pressure: Absolute pressure refers to the pressure in MPa relative to ideal vacuum; gauge pressure refers to the pressure in MPa relative to atmospheric pressure.

Example: 1 atmosphere equals 0.1013MPa absolute pressure. Gauge pressure plus 0.1013MPa equals absolute pressure.

Steam pressure/temperature: The pressure of saturated steam corresponds to the saturation temperature.

Example: The saturation temperature corresponding to the gauge pressure of saturated steam of 2 bar is 133.56°C.

Sensible heat of saturated water: The heat required to heat 1kg of water from 0°C to the boiling point under a certain pressure, and the unit of heat is kJ.

Latent heat or heat of evaporation: Under a certain pressure, the heat required to heat 1 kg of water into steam of the same pressure is called the heat of evaporation. On the contrary, the heat released by cooling 1 kg of steam of a certain pressure into condensed water of the same pressure is called latent heat. The unit of heat is kJ.

Total heat of steam: latent heat of steam + sensible heat of condensed water is the total heat of steam, that is, all heat above zero under a certain pressure.

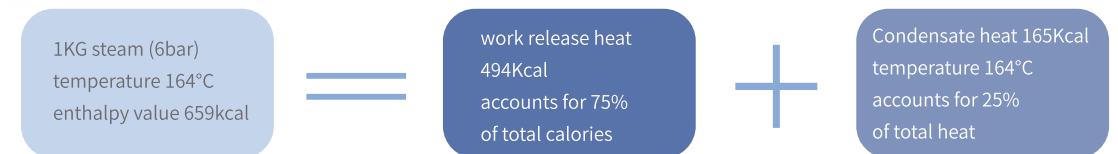

Measures for Efficient Utilization of Steam Thermal Energy

- Use superheated steam for steam delivery as much as possible.
- Reduce steam pressure and increase steam latent heat through pressure reducing valve Set or temperature & pressure reduction device.
- Improve the steam utilization rate, do a good job of heat preservation, reasonably select different types and different displacement traps, and use high-quality steam traps to prevent leakage.
- Recover the heat of the condensed water and make full use of the sensible heat of the condensed water. Use flash tank to extract low-pressure steam, back pressure to recover condensate, pump trap to recover condensate, electric pump to recover condensate, flash steam, heat exchanger to extract heat energy, etc.
- Recovery of spent steam through direct and indirect heat exchangers and heat pump suction.
- Use multi-stage heating to improve equipment steam utilization, such as double-effect, multi-effect concentration; multi-stage air preheating heating coil.
- Attach great importance to the removal of non-condensable gases from pipes and equipment.
- Reasonable piping to prevent steam airlock.

Properties of Steam

Properties of Steam

Gauge bar	Saturation Temperature °C	Sensible heat of water (specific enthalpy) kcal/kg	Latent heat of evaporation (specific enthalpy) kcal/kg	Total heat of steam (specific enthalpy) kcal/kg	Steam density kg/m ³	Density of water kg/m ³
0	99.63	99.73	539.23	638.96	0.590	958.59
0.5	111.38	111.59	531.72	643.31	0.862	949.94
1	120.24	120.58	525.88	646.46	1.129	942.95
1.5	127.44	127.91	521.01	648.92	1.391	937.03
2	133.56	134.15	516.78	650.93	1.651	931.79
2.5	138.89	139.61	513.02	652.63	1.907	927.13
3	143.64	144.49	509.6	654.09	2.162	922.93
3.5	147.94	148.91	506.46	655.37	2.416	918.95
4	151.87	152.96	503.54	656.5	2.668	915.33
4.5	155.49	156.71	500.81	657.52	2.918	911.16
5	158.86	160.2	498.23	658.43	3.168	908.6
5.5	162.02	163.48	495.78	659.26	3.417	904.9
6	164.98	166.57	493.45	660.02	3.666	902.61
6.5	167.79	169.49	491.22	660.71	3.913	899.2
7	170.44	172.27	489.08	661.35	4.160	897.02
7.5	172.97	174.92	487.01	661.94	4.407	893.97
8	175.39	177.45	485.02	662.48	4.653	891.9
8.5	177.70	179.88	483.1	662.98	4.899	889.05
9	179.92	182.22	481.23	663.45	5.144	887.15
9.5	182.05	184.47	479.42	663.89	5.390	884.88
10	184.10	186.64	477.66	664.3	5.635	882.61
10.5	186.08	188.74	475.94	664.68	5.880	880.51
11	188.00	190.77	474.27	665.04	6.125	878.35
11.5	189.85	192.74	472.63	665.37	6.369	876.35
12	191.64	194.65	471.03	665.68	6.614	874.28
12.5	193.39	196.51	469.47	665.97	6.858	872.37
13	195.08	198.32	467.93	666.25	7.103	870.4
13.5	196.72	200.08	466.43	666.51	7.347	868.51
14	198.33	201.8	464.95	666.75	7.592	866.7
14.5	199.89	203.48	463.5	666.97	7.836	864.9
15	201.41	205.11	462.07	667.19	8.081	863.11
15.5	202.90	206.71	460.67	667.39	8.326	861.33
16	204.35	208.28	459.29	667.57	8.570	859.62
16.5	205.76	209.81	457.93	667.75	8.815	857.93
17	207.15	211.32	456.6	667.91	9.060	856.24

Gauge bar	Saturation Temperature °C	Sensible heat of water (specific enthalpy) kcal/kg	Latent heat of evaporation (specific enthalpy) kcal/kg	Total heat of steam (specific enthalpy) kcal/kg	Steam density kg/m ³	Density of water kg/m ³
17.5	208.51	212.79	455.28	668.07	9.305	854.63
18	209.84	214.23	453.98	668.21	9.550	853.02
18.5	211.14	215.65	452.69	668.35	9.796	851.43
19	212.42	217.04	451.43	668.47	10.041	849.83
19.5	213.67	218.41	450.18	668.59	10.287	850.48
20	214.90	219.76	448.94	668.69	10.533	846.81
20.5	216.10	221.08	447.72	668.79	10.779	845.24
21	217.29	222.38	446.51	668.89	11.025	843.81
21.5	218.45	223.66	445.32	668.97	11.272	842.32
22	219.60	224.92	444.14	669.05	11.519	840.83
22.5	220.72	226.16	442.97	669.12	11.766	839.42
23	221.83	227.38	441.81	669.19	12.013	838.01
23.5	222.92	228.58	440.67	669.25	12.260	836.61
24	223.99	229.77	439.53	669.3	12.508	835.21
24.5	225.05	230.94	438.41	669.35	12.756	833.82
25	226.09	232.1	437.3	669.39	13.004	832.43
25.5	227.11	233.24	436.19	669.43	13.253	831.12
26	228.12	234.36	435.1	669.46	13.502	829.74
26.5	229.11	235.48	434.01	669.49	13.751	828.43
27	230.10	236.57	432.94	669.51	14.000	827.13
27.5	231.06	237.66	431.87	669.53	14.250	825.83
28	232.02	238.73	430.81	669.54	14.500	824.54
28.5	232.96	239.79	429.76	669.55	14.750	823.25
29	233.89	240.83	428.72	669.56	15.001	821.96
29.5	234.81	241.87	427.69	669.56	15.252	820.75
30	235.72	242.89	426.66	669.55	15.504	819.47
30.5	236.61	243.9	425.64	669.54	15.755	816.99
31	237.50	244.91	424.63	669.54	16.007	814.6
31.5	238.37	245.9	423.62	669.52	16.260	812.22
32	239.24	246.88	422.62	669.5	16.513	809.85
32.5	240.09	247.85	421.63	669.48	16.766	807.49
33	240.94	248.81	420.64	669.46	17.019	805.22
33.5	241.77	249.76	419.66	669.43	17.273	802.95
34	242.60	250.71	418.69	669.4	17.527	800.7
34.5	243.41	251.64	417.72	669.36	17.782	798.47

Condensate Pipe Diameter/Velocity/Flow table

Professional Terms

DN	Flow m ³ /h													
	0.4m/s	0.6m/s	0.8m/s	1.0m/s	1.2m/s	1.4m/s	1.6m/s	1.8m/s	2.0m/s	2.2m/s	2.4m/s	2.6m/s	2.8m/s	3.0m/s
20	0.5	0.7	0.9	1.1	1.4	1.6	1.8	2	2.3	2.5	2.7	2.9	3.2	3.4
25	0.7	1.1	1.4	1.8	2.1	2.5	2.8	3.2	3.5	3.9	4.2	4.6	4.9	5.3
32	1.2	1.7	2.3	2.9	3.5	4.1	4.6	5.2	5.8	6.4	6.9	7.5	8.1	8.7
40	1.8	2.7	3.6	4.5	5.4	6.3	7.2	8.1	9	10	10.9	11.8	12.7	13.6
50	2.8	4.2	5.7	7.1	8.5	9.9	11.3	12.7	14.1	15.6	17	18.4	19.8	21.2
65	4.8	7.2	9.6	11.9	14.3	16.7	19.1	21.5	23.9	26.3	28.7	31.1	33.4	35.8
80	7.2	10.9	14.5	18.1	21.7	25.3	29	32.6	36.2	39.8	43.4	47	50.7	54.3
100	11.3	17	22.6	28.3	33.9	39.6	45.2	50.9	56.5	62.2	67.9	73.5	79.2	84.8
125	17.7	26.5	35.3	44.2	53	61.9	70.7	79.5	88.4	97.2	106	114.9	123.7	132.5
150	25.4	38.2	50.9	63.6	76.3	89.1	101.8	114.5	127.2	140	152.7	165.4	178.1	190.9
200	45.2	67.9	90.5	113.1	135.7	158.3	181	203.6	226.2	248.8	271.4	294.1	316.7	339.3
250	70.7	106	141.4	176.7	212.1	247.4	282.7	318.1	353.4	388.8	424.1	459.5	494.8	530.1
300	101.8	152.7	203.6	254.5	305.4	356.3	407.1	458	508.9	559.8	610.7	661.6	712.5	763.4
350	138.5	207.8	277.1	346.4	415.6	484.9	554.2	623.4	692.7	762	831.3	900.5	969.8	1039.1
400	181	271.4	361.9	452.4	542.9	633.3	723.8	814.3	904.8	995.3	1085.7	1176.2	1266.7	1357.2
450	229	343.5	458	572.6	687.1	801.6	916.1	1030.6	1145.1	1259.6	1374.1	1488.6	1603.2	1717.7
500	282.7	424.1	565.5	706.9	848.2	989.6	1131	1272.3	1413.7	1555.1	1696.5	1837.8	1979.2	2120.6
600	407.1	610.7	814.3	1017.9	1221.4	1425	1628.6	1832.2	2035.7	2239.3	2442.9	2646.5	2850	3053.6

Technical Standard

GB/T12250-2005 "Steam Trap Terminology Marking Structure Length"	JB/T53169-1994 "Quality Classification of Steam Traps"
GB/T22654-2008 "Technical Conditions for Steam Traps"	JB/T 7928 "General Valve Supply Requirements"
GB/T12251-2005 "Test methods for steam traps"	JB/T 308 "valve model compilation method"

Professional Terms

Nominal diameter DN: It is the size expressed by a number that is common to all accessories in the piping system. The parts identified by thread or outer diameter have been distinguished. The nominal diameter is a convenient original integer for reference.

Nominal pressure PN: It is a pressure-related identification code expressed in numbers, and is a convenient original integer for reference.

Working pressure PO: Valve pressure at the applicable medium temperature.

Maximum operating pressure PMO: Under correct operating conditions, the maximum pressure at the inlet end of the trap.

Maximum allowable pressure PMA: At a given temperature, the maximum pressure that the trap casing can withstand permanently.

Minimum operating pressure POM: Min. operating pressure Under correct operating conditions, the minimum pressure at the inlet end of the trap.

Working back pressure: It is the pressure at the outlet end of the steam trap under working conditions.

Maximum working back pressure: It is the maximum pressure at the outlet end of the steam trap when it can operate correctly under the maximum working pressure.

Back pressure rate: The percentage of working back pressure and working pressure.

Working pressure difference: The difference between the working pressure and the working back pressure .

Maximum working pressure difference: between the maximum working pressure and the maximum working back pressure of Max operating different pressure.

Operating temperature TO: valve temperature in the applicable medium.

Maximum operating temperature TMO: The maximum temperature that the medium is allowed to use under the specified pressure.

Maximum allowable temperature TMA: The maximum temperature that the trap casing can withstand permanently under a given pressure.

Sub cooled temperature: The absolute value of the difference between the condensate temperature and the saturation temperature at the corresponding pressure.

Cold condensate capacity quantity QC: The steam trap can drain maximum weight of condensate within one hour at a given differential pressure and 20°C .

Hot condensate capacity QH: The maximum weight of condensate that the steam trap can discharge within one hour at a given pressure difference and temperature.

Steam loss quantity QL: The amount of fresh steam leaking from the steam trap per unit time.

No load steam loss quantity QNL: The quantity of leaked steam under the condition of fully saturated steam before the steam trap.

Loads steam loss quantity QLL: The steam leakage quantity of the steam trap under a given load rate.

Steam Trap

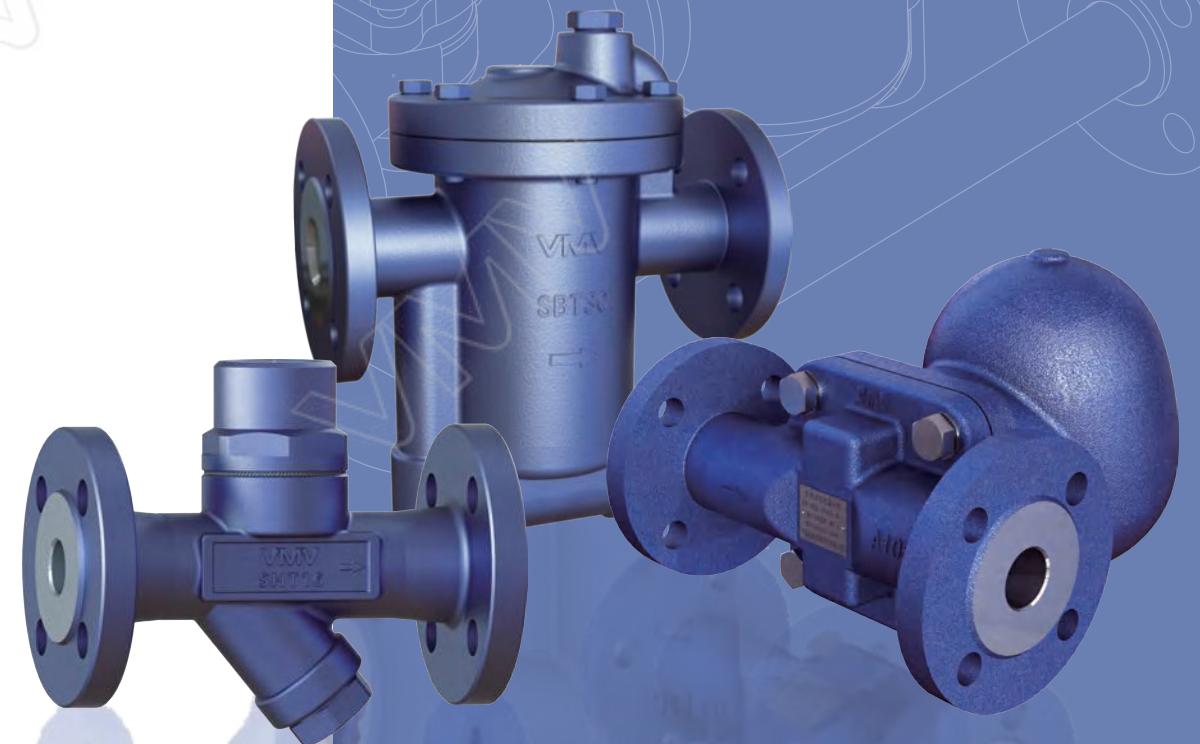

Thermostatic(Bimetallic)Steam Trap

Thermostatic(film box)Steam Trap

SHT21 Thermostatic(Bimetallic)Steam Trap



Technical Parameters

Nominal pressure	PN25
Max. allowable pressure(Shell)	2.45MPa/200°C
Max. allowable temperature(Shell)	450°C/1.03MPa
Factory steam action test	>3 times/1.6MPa
Max. working pressure	2.1MPa
Max. operating temperature	350°C
Factory cold test pressure	3.8MPa
Air test	2.0MPa

Differential Pressure Bar

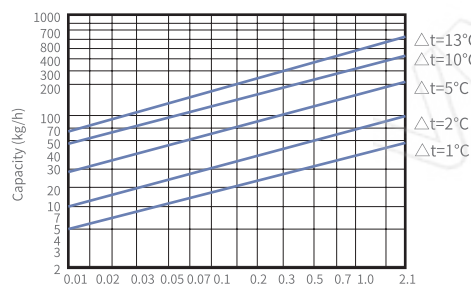
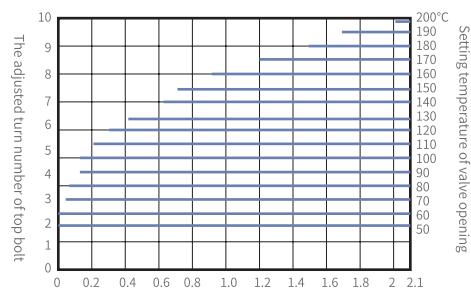

Differential Pressure (MPa) ▲t= Setting temperature-Valve actual drainage temperature

Working Principle

- The working principle of the bimetallic trap is to rely on the different temperature between saturated steam and condense water.
- When the set temperature is reached, the condensed water is continuously removed.

Features

- The body and bonnet are all made of forged steel A105.
- The disc and seat are made of special stainless steel with heat treatment.The disc hardness is as high as HRC55, which improves the service life of the steam trap.
- Imported bimetallic ensure precise temperature control.
- The closing system adopts high-precision wire sealing structure.
- Built-in filter makes the trap work in a clean environment.
- The back pressure rate is as high as 50% or more.

Technical Standard

- GB/T12250-2005 Steam Traps Terminology Marking Structure Length
 - GB/T22654-2008 Technical Conditions for Steam Traps
 - GB/T12251-2005 Test Method for Steam Traps
 - ISO 6948 Automatic steam traps
- Production and performance characteristic tests

Structure Diagram

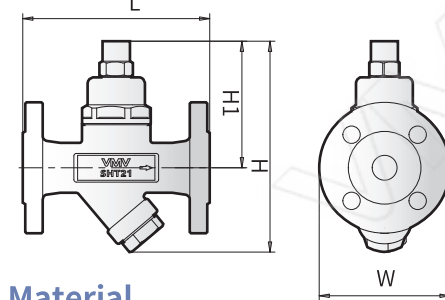

Material

- Bonnet:** A105/F304/F316
- Body:** A105/F304/F316
- Seat:** Martensitic stainless steel
- Disc:** Martensitic stainless steel
- Other internal parts:** Stainless steel

Structural Dimension Table

Model	Nominal size	L	H	H1	W	Weight
SHT21T	DN15-25	90	168	100	55	1.8 Kg
SHT21W	DN15-25	90	168	100	55	1.8 Kg
SHT21F	DN15-25	150	168	100	155	4 Kg

unit (mm)

Bimetallic steam trap station SHT21TVS

Working Principle

- The working principle of the bimetallic steam trap is to rely on the Different temperature between saturated steam and condensed water
- When the set temperature is reached, the condensate is continuously drained Features

Features

The thermostatic (bimetallic) steam trap station is a TVS station composed of stainless steel bimetallic steam traps and front and rear stainless steel valves, filters and inspection valves; the steam traps and TVS stations are made of stainless steel;Adjustable temperature bimetallic sheet makes full use of the sensible heat of high temperature condensate;It is easy to replace, and there is no need to install stop valves, filters and inspection valves at the front and rear ends of the trap; the back pressure rate is as high as 50%.

Technical Standard

- GB/T12250-2005 Steam Traps Terminology Marking Structure Length
 - GB/T22654-2008 Technical Conditions for Steam Traps
 - GB/T12251-2005 Test Method for Steam Traps
 - ISO 6948 Automatic steam traps
- Production and performance characteristic tests

Material

- Trap:** F304
- Trim:** 304/420
- TVS station:** CF8

Structure Diagram

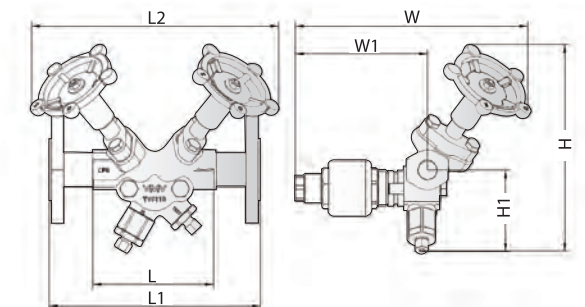

Structural Dimension Table

Model	Nominal size	L	L1	L2	W	W1	H	H1
SHT21TVS	DN15-25	90	200	220	225	128	266	120

unit (mm)



Technical Parameter

Nominal pressure	PN40/Class300
Max allowable pressure(Shell)	4.13MPa/200°C
Max allowable temperature(Shell)	450°C/3.05MPa
Max working pressure	3.2MPa
Max operating temperature	350°C
Factory cold test pressure	6.0MPa
Air test	2.0MPa

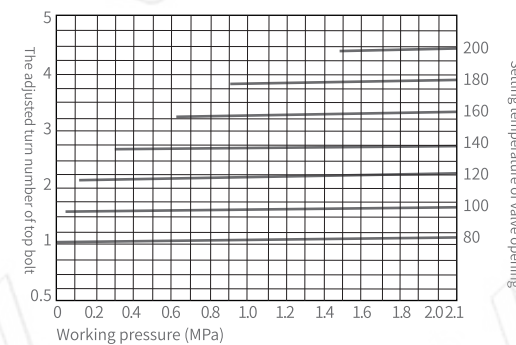

SHT21TVS Capacity Chart

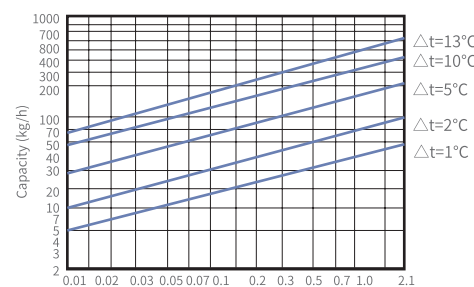

Differential Pressure (MPa) ▲t= Setting temperature-Valve actual drainage temperature

Thermostatic (film box) steam trap

Thermostatic (film box) steam trap

Film box steam traps are widely used in heat tracing pipelines and equipment with small displacement and low temperature requirements due to their small size, large subcooling degree, good energy saving effect and low temperature resistance.

The technical advantages of VMV steam traps are unique and reasonable structure and high-precision internal parts.

High Corrosion Resistance

Stainless steel SS304 has beautiful appearance and good performance.



Integrated Filtration Design

Effectively prevent pipeline impurities from entering the valve to ensure the proper operation of the steam trap.

Suitable For Clean Pipes

All internal parts are made of stainless steel SS304, suitable for food, medicine and other industries.

Large Subcooling Film Box Module

The subcooling degree of the Thermostatic (film box) steam trap is 15°C to remove the condensed water below the saturation temperature, and the energy saving is effective.



Structural Features

VMV Film box steam trap body and bonnet are made of 304, which can be used in the clean environment, such as medical, health, food and other industries. The Film box is made of stainless steel, and the condensate discharge temperature is subcooled at 15-20°C. The Film box steam trap adopts linear sealing closing system, which has no noise, good air exhausting capacity, fully utilizes the sensible heat of condensed water, and has good energy saving effect. Film box steam traps work on the difference in temperature between steam and condensate. When the steam in the pipe releases heat and the temperature decreases to produce condensate, the diaphragm in the diaphragm box shrinks and moves to open the valve seat to discharge condensate. The Film box steam trap can be used as a vent valve.

Steam Trap Election and Installation

Film box steam trap drains intermittently. The normal product SKT16 discharges subcooling at 15-20°C. If there is a subcooling requirement, please specify it when ordering. The back pressure rate of the Film box steam trap can reach 50% (rear end pipe pressure/steam pressure), which is not suitable for closed recovery system, but suitable for pipeline and heat tracing system to remove condensate. In general, the safety factor is 2-3 times.

Special reminder: The amount of condensed water and the differential pressure of the steam-using equipment are important indicators for the selection. The same type of steam trap will increase the displacement with the increase of the differential pressure. See the details on displacement curve. Please do not mistakenly think that the large diameter of the steam trap with large displacement.

Technical Standard

- GB/T12250-2005 Steam Traps Terminology Marking
 - GB/T22654-2008 Technical Conditions for Steam Traps
 - GB/T12251-2005 Test Method for Steam Traps
 - ISO 6948 Automatic steam traps
- Production and performance characteristic tests

304 Material PN16 Valve Body Pressure-Temperature Ratings

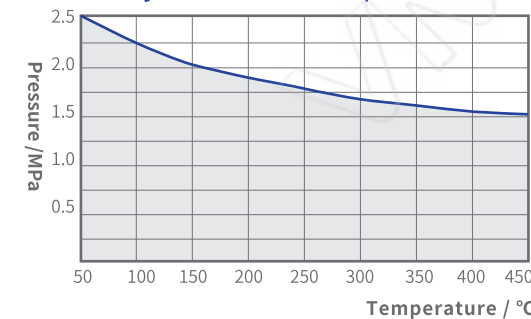

Structure Diagram

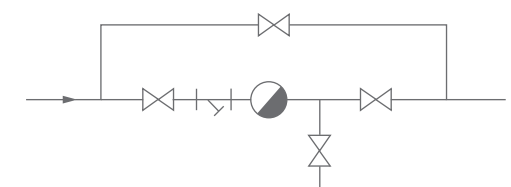

VMV Film box steam traps can be installed at any position on pipelines or equipment. The basic configuration of the steam traps is shown in the figure above.

Thermostatic (film box) steam trap

Bimetallic steam trap station

SKT16 Thermostatic (film box) steam trap

Thermostatic(Bimetallic)Steam Trap **SHT1**



Working Principle

- The working principle of the film box steam trap depends on the temperature difference between the vapor and the liquid.

Features

- The body and cover are made of 304 material.
- The disc and seat are made of special stainless steel with heat treatment. The disc hardness is as high as HRC55, which improves the service life of the trap.
- Imported film box ensures precise temperature control.
- The closing system adopts high-precision spherical linear sealing structure.
- Built-in filter makes the trap work in a clean environment.
- The back pressure rate is as high as 50% or more.

Technical Standard

- GB/T12250-2005 Steam Traps Terminology Marking Structure Length
- GB/T22654-2008 Technical Conditions for Steam Traps
- GB/T12251-2005 Test Method for Steam Traps
- ISO 6948 Automatic steam traps Production and performance characteristic tests

Structure Diagram

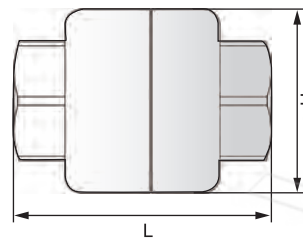

Structural Dimension Table

Model	Nominal size	L	H	Weight
SKT16T	DN15-20	75	55	1Kg
SKT16T	DN25	80	55	1.2Kg
SKT16F	DN15-25	120	125	3.8 Kg

Technical Parameter

Nominal pressure	PN25
Max. allowable pressure(Shell)	1.89MPa/200°C
Max. allowable temperature(Shell)	350°C/1.62MPa
Factory steam action test	>3 times/1.6MPa
Max. working pressure	1.6MPa
Max. operating temperature	204°C
Factory cold test pressure	3.8MPa
Air test	0.6MPa

Material

- Bonnet: SS304/SS316
- Body: SS304/SS316
- Seat: Martensitic stainless steel
- Valve core: Martensitic stainless steel
- Other internal parts: Austenitic Stainless Steel

SKT16 Capacity Chart

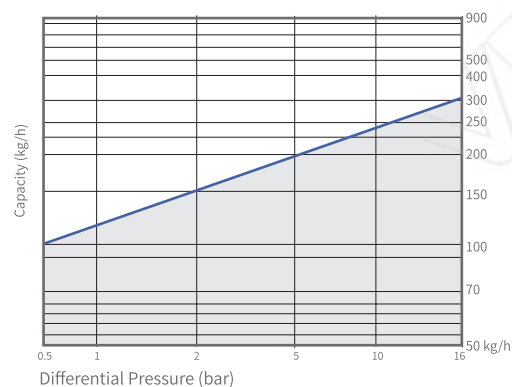

Working Principle

- The working principle of the bimetallic steam trap is to rely on the different temperature between saturated steam and condense water.
- When the set temperature is reached, the condensed water is

Features

- The body and bonnet are all made of forged steel A105.
- The disc and seat are made of special stainless steel with heat treatment. The disc hardness is as high as HRC55, which improves the service life of the steam trap.
- Imported bimetallic ensure precise temperature control.
- The closing system adopts high-precision wire sealing structure.
- Built-in filter makes the trap work in a clean environment.
- The back pressure rate is as high as 50% or more.

Technical Parameters

Nominal pressure	PN25
Max. allowable pressure(Shell)	2.45MPa/200°C
Max. allowable temperature(Shell)	450°C/1.03MPa
Factory steam action test	>3 times/1.6MPa
Max. working pressure	1.6MPa
Max. operating temperature	350°C
Factory cold test pressure	3.8MPa
Air test	2.0MPa

Material

- Bonnet: 420
- Body: 420
- Seat: Martensitic stainless steel
- Disc: Martensitic stainless steel
- Other internal parts: Stainless steel

Temperature Adjustment Table

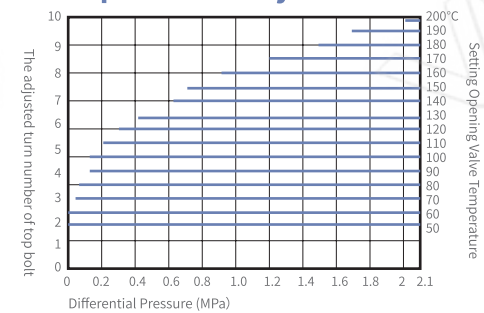

Technical Standard

- GB/T12250-2005 Steam Traps Terminology Marking Structure Length
- GB/T22654-2008 Technical Conditions for Steam Traps
- GB/T12251-2005 Test Method for Steam Traps
- ISO 6948 Automatic steam traps Production and performance characteristic tests

Structure Diagram

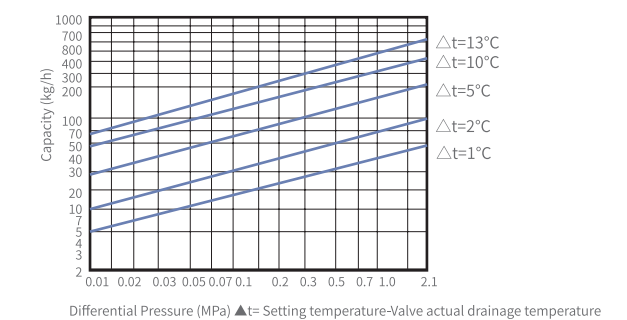
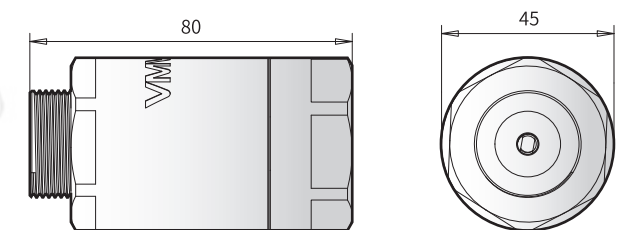

Thermodynamic (Disc) Steam Trap

Thermodynamic (Disc) Steam Trap

Thermodynamic steam traps are widely used in low, medium and high pressure steam pipelines, process heat tracing, and small displacement equipment due to their small size, large displacement, energy saving, long life, and low temperature resistance.

The technical advantages of VMV steam traps are unique and reasonable structure, high-precision internal parts, changeable valve seat.

High Corrosion Resistance

A105 (15CrMo) material is used, and corrosion allowance, minimum shell wall thickness, pressure and temperature grade are fully considered in the design.

Unique Seat and Disc

The seat and plate are made of martensitic stainless steel with unique heat treatment. According to different working conditions, two kinds of condensate removal solutions of low temperature (less flash steam) and saturated water can be provided

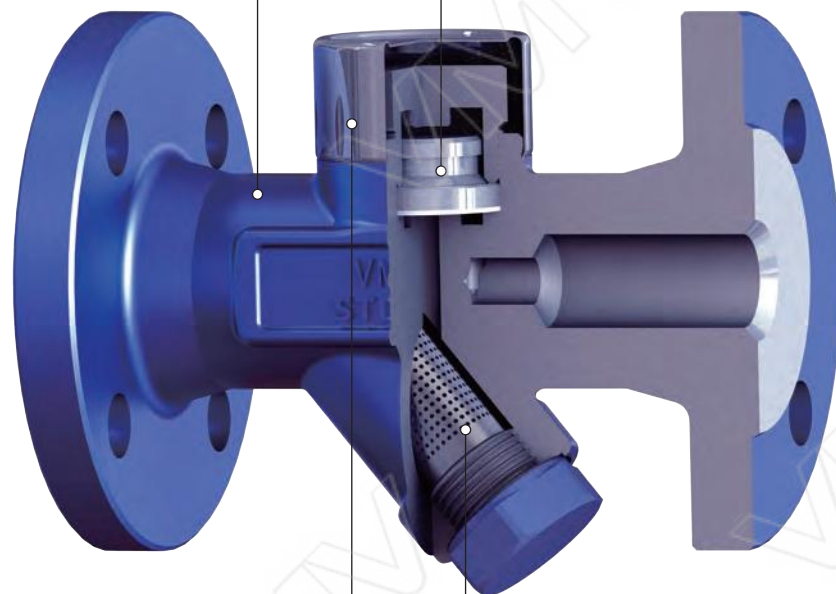

Stainless Steel Insulation Cover

Stainless steel thermal insulation cover ensures that the transformer room is not affected by the outdoor environment and prevents invalid actions.

Built-in Filter

Effectively prevent pipeline impurities from entering the valve, make sure the steam trap is working properly.

Structural Features

VMV thermodynamic steam trap uses A105 for the low pressure trap body and 15CrMo for the medium pressure steam trap body. According to the Bernoulli equation, it has been repeatedly calculated and finally finalized through a large number of experiments. The product is available in low temperature and saturated versions. The low-temperature type discharges the condensate at a lower temperature (higher degree of subcooling) and has less noise, but the air discharge capacity is poor; the saturated type discharges the condensed water close to the saturation temperature (low degree of subcooling), with high noise and good air discharge capacity. Thermodynamic steam traps operate on the difference in flow rates between steam and condensate. When the condensate passes through the valve seat, the flow rate is small, and the valve plate is opened to discharge the condensate water; when the steam enters the valve seat, the valve seat is closed due to the large flow rate.

VMV Newton has broken through the problems that thermodynamic steam traps are not energy-saving, noisy, and discharges raw steam, and has become the best steam pipe guide steam trap. Its advantages are small size, long life, reliable action, convenient maintenance, and low noise (Low temperature type) no original steam leakage

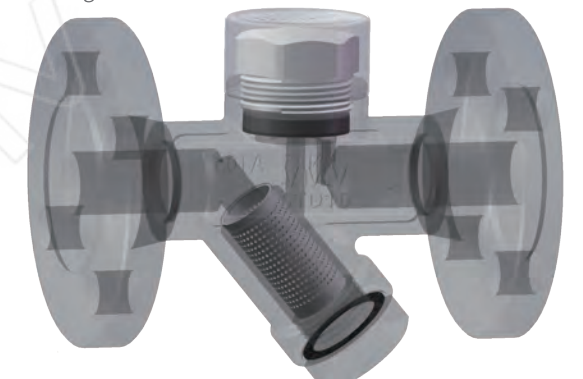

A105 Material PN25

Valve Body Pressure-Temperature Ratings

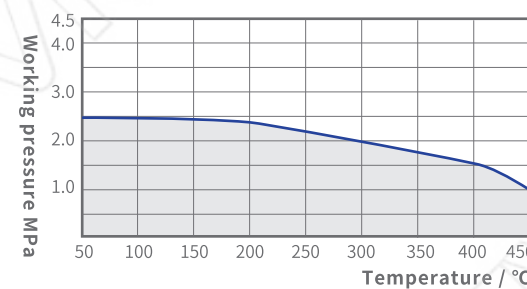

A105 Material PN63

Valve Body Pressure-Temperature Ratings

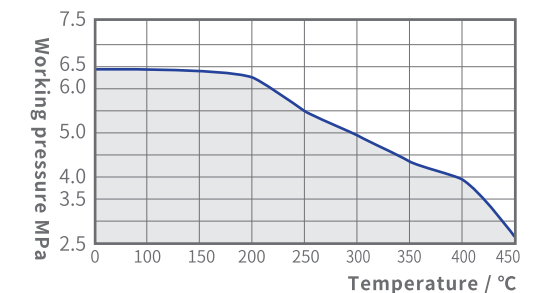

Thermodynamic Trap Selection and Installation

The thermodynamic steam trap is intermittently drained, and the normal product STD16/STD42 steam trap has a subcooling degree of 5-10°C. The back pressure rate of the thermodynamic steam trap can reach 80% (rear pipe pressure/steam pressure), and it is suitable for pipes and small equipment to remove condensate. In general, the safety factor is 2-3 times.

Special reminder: The amount of condensate and the differential pressure of the steam-using equipment are important indicators for selection. The same type of trap will increase the capacity with the increase of the differential pressure. See the details on capacity curve. Please do not mistakenly think that the large diameter of the trap with large displacement.

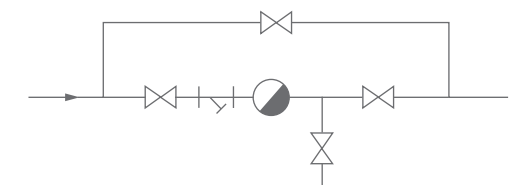

Thermodynamic steam traps can be installed arbitrarily at the bottom of the pipeline or equipment. The basic configuration of the steam traps is shown in the figure above.

Thermodynamic (Disc) Steam Trap

Thermodynamic (Disc) Steam Trap

STD01 Thermodynamic (Disc) Steam Trap

Thermodynamic (Disc) Steam Trap STD16

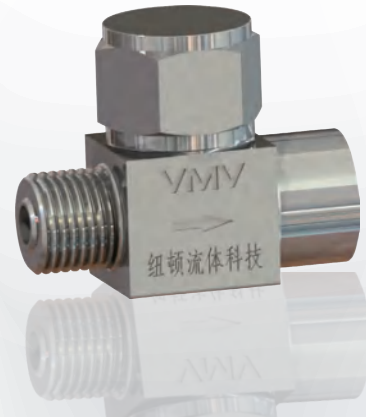

Working Principle

- Depends on the difference of steam and liquid flow rate
- Exclude saturated condensate

Features

- The body and bonnet are all made of stainless steel. Through heat treatment and aging treatment, they are not denatured and wear-resistant under high temperature and high pressure, which improves the service life of the trap.
- The fluid channel of the internal structure is designed strictly according to Bernoulli's equation, and the structure is reasonable.
- The back pressure rate is as high as 80% or more.

Technical Standard

- GB/T12250-2005 Steam Traps Terminology Marking Structure Length
 - GB/T22654-2008 Technical Conditions for Steam Traps
 - GB/T12251-2005 Test Method for Steam Traps
 - ISO 6948 Automatic steam traps
- Production and performance characteristic tests

Structure Diagram

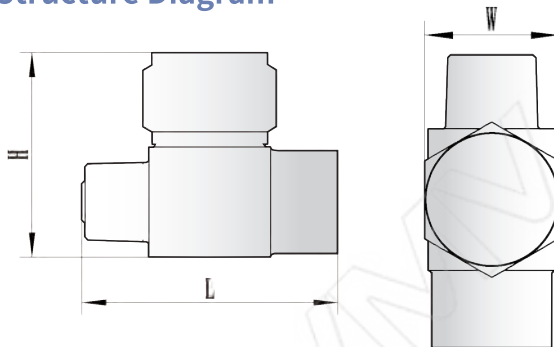

Structural Dimension Table

Model	Size	L	H	W	Weight
STD01	1/4"	42	34	18	0.115Kg

- Suitable for steam irons and instrument pads in the garment

Technical Parameter

Nominal pressure	PN16
Max. allowable pressure (Shell)	1.51MPa/50°C
Max. allowable temperature (Shell)	200°C/1.09MPa
Factory steam action test	>3 times/1.0MPa
Max. working pressure	1.0MPa
Max. operating temperature	200°C
Factory cold test pressure	2.4MPa
Air test	0.6MPa

Material List

- Bonnet:** 304
- Body:** Martensitic Stainless Steel
- Disc:** Martensitic Stainless Steel

STD01 Capacity Chart

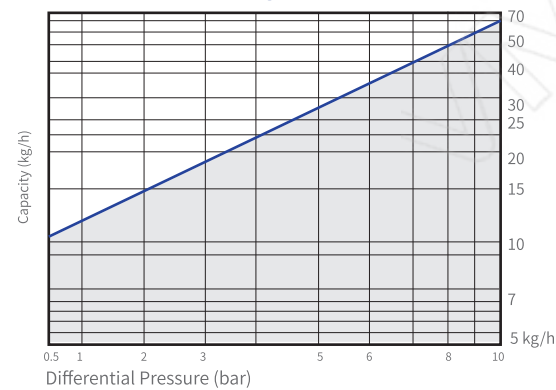

Working Principle

- Depends on the difference of steam and liquid flow rate
- Exclude saturated condensate

Features

- The body and cover are all made of forged steel.
- The disc and seat are made of martensitic stainless steel. After heat treatment and aging treatment, they are not denatured and wear-resistant under high temperature and high pressure, which improves the service life of the trap.
- Stainless steel insulation cover to isolate and slow down heat loss and eliminate invalid actions.
- The fluid channel of the internal structure is designed strictly according to Bernoulli's equation, and the structure is reasonable.
- Built-in filter makes the trap work in a clean environment.
- The back pressure rate is as high as 80% or more.
- To exclude low temperature traps with large subcooling degree, it needs to be customized.

Technical Standard

- GB/T12250-2005 Steam Traps Terminology Marking Structure Length
 - GB/T22654-2008 Technical Conditions for Steam Traps
 - GB/T12251-2005 Test Method for Steam Traps
 - ISO 6948 Automatic steam traps
- Production and performance characteristic tests

Structure Diagram

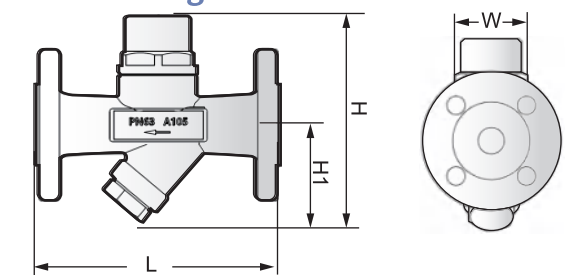

Structural Dimension Table

Model	Size	L	H	H1	W	Weight
STD16T	DN15-25	90	120	68	48	1/1.5Kg
STD16W	DN15-25	90	120	68	48	1/1.5Kg
STD16F	DN15-25	150	120	68	48	2.5-3Kg

- Suitable for drainage of saturated or superheated steam pipelines.

Technical Parameter

Nominal pressure	PN25
Max. allowable pressure (Shell)	2.45MPa/200°C
Max. allowable temperature (Shell)	450°C/1.03MPa
Factory steam action test	>3 times/1.6MPa
Max. working pressure	1.6MPa
Max. operating temperature	350°C
Factory cold test pressure	3.8MPa
Air test	2.0MPa

Material List

- Bonnet:** A105/F304/F316
- Body:** A105/F304/F316
- Seat:** Martensitic stainless steel
- Disc:** Martensitic stainless steel
- Other internal parts:** Martensitic stainless steel

STD16 Capacity Chart

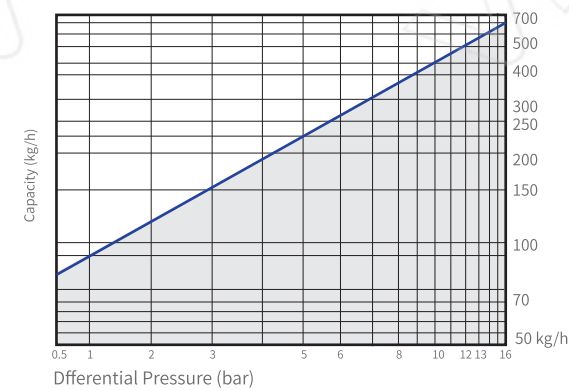

Thermodynamic (Disc) Steam Trap

Thermodynamic (Disc) Steam Trap

STD42 Thermodynamic (Disc) Steam Trap

Thermodynamic (Disc) Steam Trap STD80

working Principle

- Depends on the difference of steam and liquid flow rate
- Exclude saturated condensate

Features

- The body and cover are all made of forged steel.
- The disc and seat are made of special stainless steel, which is heat treated And aging treatment, no deformation and wear resistance under high temperature and high pressure, improve the service life of the trap.
- Stainless steel insulation cover to isolate and slow down heat loss and prevent the trap from emptying up phenomenon.
- The fluid channel of the internal structure is designed strictly according to Bernoulli's equation, and the structure is reasonable.
- Built-in filter makes the trap work in a clean environment.
- The back pressure rate is as high as 80% or more.
- To exclude low temperature traps with large subcooling degree, it needs to be customized.

Technical Standard

- GB/T12250-2005 Steam Traps Terminology Marking Structure Length
- GB/T22654-2008 Technical Conditions for Steam Traps
- GB/T12251-2005 Test Method for Steam Traps
- ISO 6948 Automatic steam traps
Production and performance characteristic tests

Structure Diagram

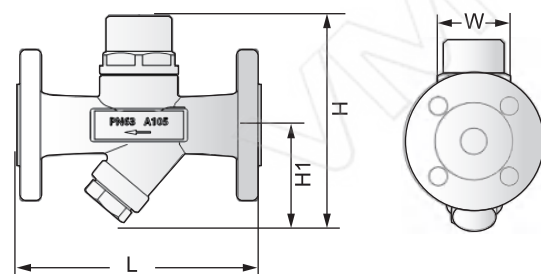

Structural Dimension Table

Model	Size	L	H	H1	W	Weight
STD42T	DN15-25	90	126	68	55	1.8 Kg
STD42W	DN15-25	90	126	68	55	1.8 Kg
STD42F	DN15-25	150	126	68	55	5.5Kg

- Suitable for saturated or superheated steam pipeline drainage



Technical Parameter

Nominal pressure	PN63
Max. allowable pressure (Shell)	6.27MPa/200°C
Max. allowable temperature (Shell)	450°C/2.6MPa
Factory steam action test	>3次/1.6MPa
Max. operating pressure	4.2MPa
Max. operating temperature	350°C
Factory cold test pressure	9.5MPa
Air test	2.0MPa

Material List

Bonnet: A105/F304/F316 Disc: Martensitic stainless steel
 Body: A105/F304/F316 Other internal parts:
 Seat: Martensitic stainless steel Martensitic stainless steel

STD42 Capacity Chart

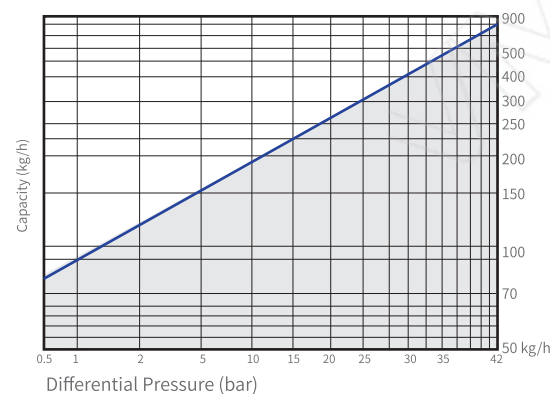

working Principle

Depends on the difference of steam and liquid flow rate.

Features

- The disc and seat are made of special stainless steel, which is heat treated and aging treatment, no deformation and wear resistance under high temperature and high pressure, improve the service life of the trap.
- Stainless steel insulation cover to isolate and slow down heat loss and prevent the trap from emptying up phenomenon.
- The fluid channel of the internal structure is designed strictly according to Bernoulli's equation, and the structure is reasonable.
- Built-in filter makes the trap work in a clean environment.
- The back pressure rate is as high as 80% or more.

Technical Parameter

Nominal pressure	PN100
Max. allowable pressure (Shell)	9.8MPa/200°C
Max. allowable temperature (Shell)	450°C/7.29MPa
Factory steam action test	>3 times/1.6MPa
Max. operating pressure	8.0MPa
Max. operating temperature	420°C
Factory cold test pressure	15.0MPa
Air test	2.0MPa

Material List

Bonnet: 15CrMo Disc: Martensitic stainless steel
 Body: 15CrMo Other trims: Martensitic stainless steel
 Seat: Martensitic stainless steel

STD80 Capacity Chart

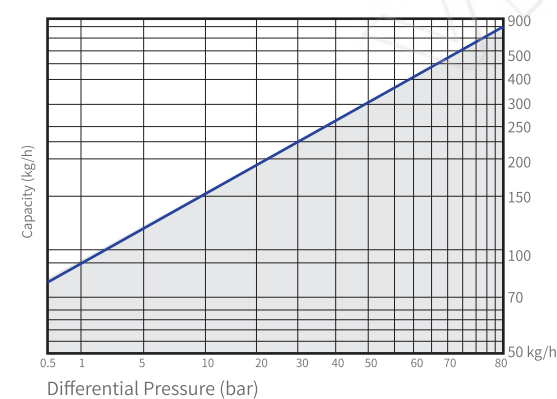

Technical Standard

- GB/T12250-2005 Steam Traps Terminology Marking Structure Length
- GB/T22654-2008 Technical Conditions for Steam Traps
- GB/T12251-2005 Test Method for Steam Traps
- ISO 6948 Automatic steam traps
Production and performance characteristic tests

Structure Diagram

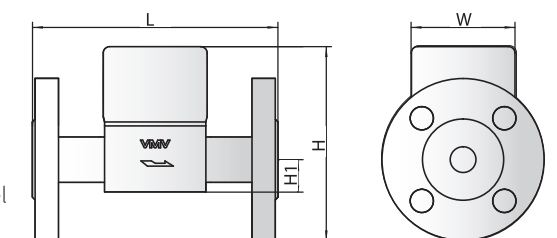

Structural Dimension Table

Model	Size	L	H	H1	W	Weight
STD80W	DN15-25	85	112	25	90	4.0Kg
STD80F	DN15-25	190	112	25	90	7.5Kg

- Suitable for saturated or superheated steam pipeline drainage.

Inverted Bucket Steam Trap

Inverted Bucket Steam Trap

Inverted bucket Steam traps are widely used in steam transmission pipelines, process heat tracing, jacketed heating kettles tank, reboilers and other equipment due to their safety, reliability, energy saving, long life, low temperature resistance and other characteristics.

The technical advantages of VMV steam traps: Unique and reasonable structure, high-precision internal parts

High Corrosion Resistance

Using WCB material
Design with full consideration of corrosion allowance, Minimum shell wall thickness, pressure and temperature class

Leak-free Structure Design

The U-shaped flow channel design ensures that the inside of the valve body is in a water-sealed state
No original steam leakage

Built-in Filter

Effectively prevent pipeline impurities from entering the valve Make sure the steam trap is working properly

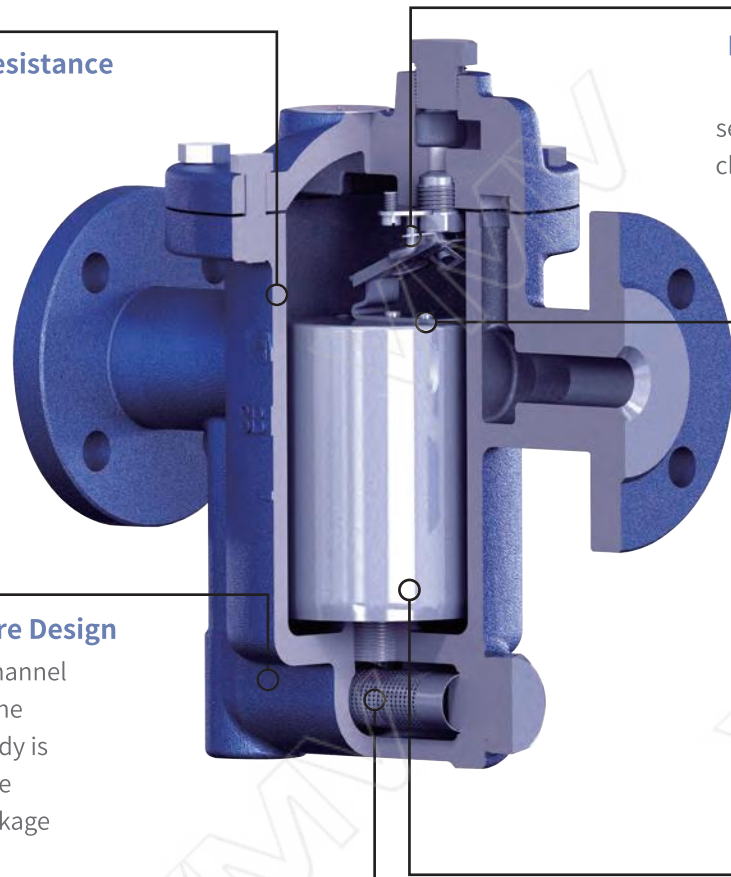

Flexible Closing System

Micron-level high-precision seat and core ensure reliable closing system and no steam leakage

Stainless Steel Bucket Exhaust Structure

Small holes are left on the upper part of the bucket to remove air and other non-condensable gases to prevent the occurrence of steam lock the steam trap

Built-in Check Valve

Prevents water hammer from damaging internals. Also suitable for superheated steam environments

Structural Features

VMV steam trap design has fully considered factors such as shell strength, pressure and temperature grade, casting manufacturability, tightness of valve plug and seat closure, impact caused by water and vapor mixing, and the strength of valve cover gasket is affected by low temperature environment and other factors .

Inverted bucket steam traps work on the difference in density between steam and condensate. When the bucket is full of condensed water and non-condensable gas, the exhaust hole on the upper part of the bucket removes the non-condensable gas, the bucket loses buoyancy and drives the valve core to move down, the trap opens to drain, and when steam enters the bucket after draining, the bucket floats to drive the valve The core closes the trap.

The great advantages of the inverted bucket trap are high back pressure rate, long life, reliable action, convenient maintenance and no original steam leakage.

WCB/A105 Material PN25 Valve Body Pressure-Temperature Ratings

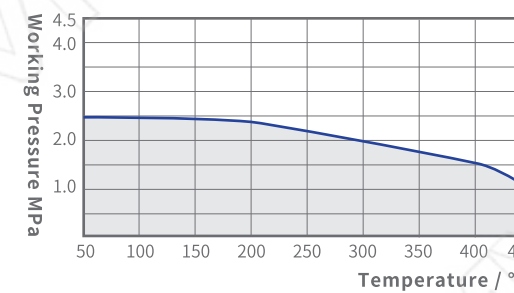

WCB/A105 Material PN63 Valve Body Pressure-Temperature Ratings

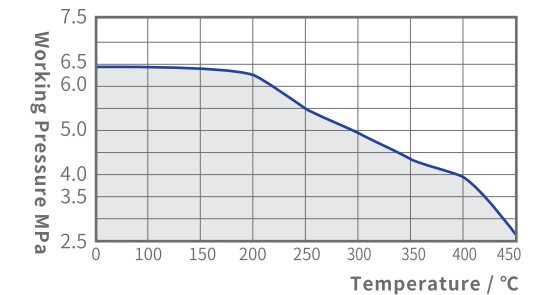

Selection and Installation of Inverted Bucket Steam Traps

The inverted bucket steam trap is intermittently drained, the subcooling degree is 5-10°C, and the back pressure rate is over 85% (back-end pipeline pressure/steam pressure). In general, the safety factor is 2-3 times when selecting, and 5-8 times for air separation units and drying cylinders. The amount of condensed water and the differential pressure of the steam-using equipment are important indicators for model selection. For the same type of steam trap, the displacement increases with the increase of the differential pressure. See the details on displacement curve.

Special reminder: Please do not mistakenly think that a trap with a large diameter has a large displacement.

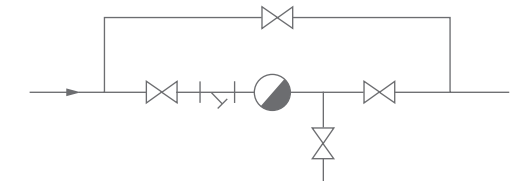

The inverted bucket trap is installed horizontally at the bottom of the pipeline or equipment. The basic configuration of the trap is shown in the figure above.

When the pipeline is superheated steam, a check valve must be installed to prevent the failure of the trap due to the superheated steam drying out the water seal in the trap.

Inverted Bucket Steam Trap

Inverted Bucket Steam Trap

SBT10A Inverted Bucket Steam Trap

Inverted Bucket Steam Trap SBT20



Working Principle

- Relying on the difference in vapor and liquid density.

Features

- The body and cover are all made of forged steel/cast steel.
- Internal parts are all made of stainless steel and added with anti-wear allowance, extend trap life.
- U-shaped flow channel design, to achieve water sealing effect, no leakage of steam.
- Reliable flexible closure system with patented technology, no steam leakage.
- Install anti-water hammer device.
- Built-in check valve, suitable for superheated steam environment.
- Built-in filter allows the steam trap to work in a clean environment.
- Select different displacement curves according to the pressure difference to increase the displacement.
- The back pressure rate is as high as 90% or more.
- After the steam is stopped, the condensed water can be removed by opening the screw plug to prevent damage to the steam trap due to low temperature freezing.

Technical Standard

- GB/T12250-2005 Steam Traps Terminology Marking Structure Length
- GB/T22654-2008 Technical Conditions for Steam Traps
- GB/T12251-2005 Test Method for Steam Traps
- ISO 6948 Automatic steam traps
Production and performance characteristic tests

Structure Diagram

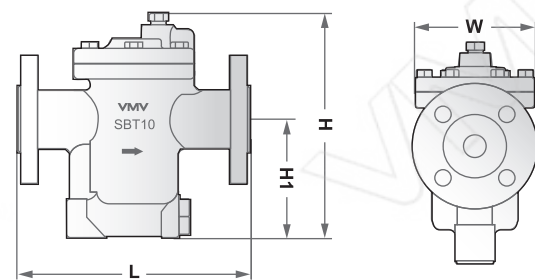

Structural Dimension Table

Model	Size	L	H	H1	W	Weight
SBT10AT	DN15-25	130	186	113	100	4Kg
SBT10AW	DN15-25	130	186	113	100	4Kg
SBT10AF	DN15-25	190	186	113	100	6.5Kg

Technical Parameter

Nominal pressure	PN25
Max. allowable pressure (Shell)	2.45MPa/200°C
Max. allowable temperature (Shell)	450°C/1.03MPa
Factory steam action test	>3 times/1.6MPa
Max. operating pressure	1.6MPa
Max. operating temperature	350°C
Factory cold test pressure	3.8MPa
Air test	2.0MPa

Material list

- Bonnet: A105/F304/F316 Disc: Martensitic stainless steel
 Body: WCB/CF8/CF8M Other internal parts:
 Seat: Martensitic Austenitic stainless steel
 stainless steel

SBT10A Capacity Chart

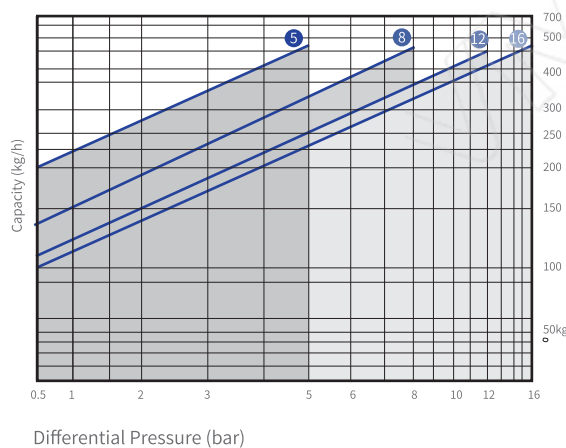

Technical Parameter

Nominal pressure	PN25
Max. allowable pressure (Shell)	2.45MPa/200°C
Max. allowable temperature (Shell)	450°C/1.03MPa
Factory steam action test	>3 times/1.6MPa
Max. operating pressure	1.6MPa
Max. operating temperature	350°C
Factory cold test pressure	3.8MPa
Air test	2.0MPa

Material List

- Bonnet : A105/F304/F316 Disc: Martensitic stainless steel
 Body : WCB/CF8/CF8M Other internal parts:
 Seat : Martensitic Austenitic stainless steel
 stainless steel

SBT20 Capacity Chart

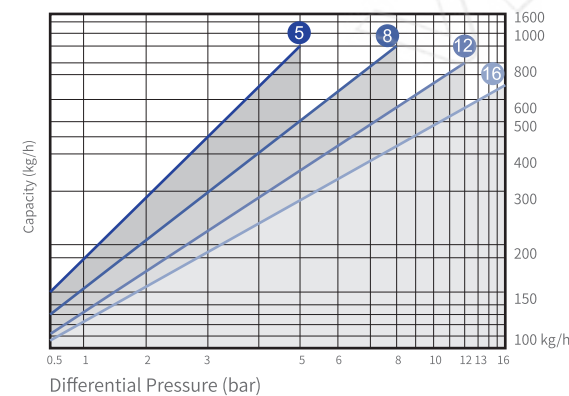

working Principle

- Relying on the difference in vapor and liquid density.

Features

- The body and cover are all made of forged steel/cast steel.
- All internal parts are made of stainless steel, and the wear allowance has been fully considered in the design of movable parts, which improves the service life of the steam trap
- U-shaped flow channel design, to achieve water sealing effect, no leakage of steam.
- Flexible closing system with patented technology, no steam leakage.
- Install anti-water hammer device.
- Built-in check valve, suitable for superheated steam environment.
- Built-in filter allows the trap to work in a clean environment.
- Select different displacement curves according to the pressure.
- The back pressure rate is as high as 90% or more.
- After the steam is stopped, the condensed water can be removed by opening the screw plug to prevent damage to the trap due to low temperature freezing.

Technical Standard

- GB/T12250-2005 Steam Traps Terminology Marking Structure Length
- GB/T22654-2008 Technical Conditions for Steam Traps
- GB/T12251-2005 Test Method for Steam Traps
- ISO 6948 Automatic steam traps
Production and performance characteristic tests

Structure Diagram

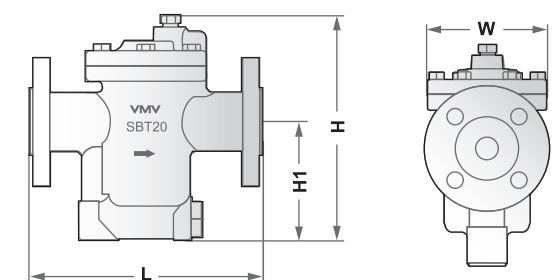

Structural Dimension Table

Model	Size	L	H	H1	W	Weight
SBT20T	DN15-25	170	245	133	140	8Kg
SBT20W	DN15-25	170	245	133	140	8Kg
SBT20F	DN15-40	230	245	133	140	10.5Kg

Inverted Bucket Steam Trap

Inverted Bucket Steam Trap

SBT24 Inverted Bucket Steam Trap

Inverted Bucket Steam Trap SBT30



Working Principle

- Relying on the difference in vapor and liquid density.

Features

- The body and cover are all made of forged steel/cast steel.
- Internal parts are all made of stainless steel and added with anti-wear allowance, extend steam trap life.
- U-shaped flow channel design, to achieve water sealing effect, no leakage of steam.
- Reliable flexible closure system with patented technology, no steam leakage.
- Install anti-water hammer device.
- Built-in check valve, suitable for superheated steam environment.
- Built-in filter allows the steam trap to work in a clean environment.
- Select different displacement curves according to the pressure difference to increase the displacement.
- The back pressure rate is as high as 90% or more.
- After the steam is stopped, the condensed water can be removed by opening the screw plug to prevent damage to the steam trap due to low temperature freezing.

Technical Standard

- GB/T12250-2005 Steam Traps Terminology Marking Structure Length
 - GB/T22654-2008 Technical Conditions for Steam Traps
 - GB/T12251-2005 Test Method for Steam Traps
 - ISO 6948 Automatic steam traps
- Production and performance characteristic tests

Structure Diagram

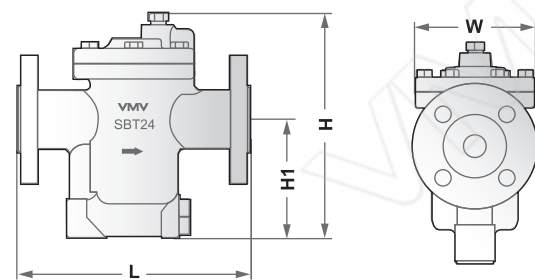

Structural Dimension Table

Model	Size	L	H	H1	W	Weight
SBT24T	DN15-40	170	250	133	140	9Kg
SBT24W	DN15-40	170	250	133	140	9Kg
SBT24F	DN15-40	230	250	133	140	12Kg

Technical Parameter

Nominal pressure	PN63
Max. allowable pressure (Shell)	6.27MPa/200°C
Max. allowable temperature (Shell)	450°C/2.6MPa
Factory steam action test	>3 times/1.6MPa
Max. working pressure	4.5MPa
Max. operating temperature	350°C
Factory cold test pressure	9.5MPa
Air test	2.0MPa

Material List

- Bonnet : A105/F304/F316
- Disc: Martensitic stainless steel
- Body : WCB/CF8/CF8M
- Other internal parts: Austenitic stainless steel
- Seat : Martensitic stainless steel

SBT24 Capacity Chart

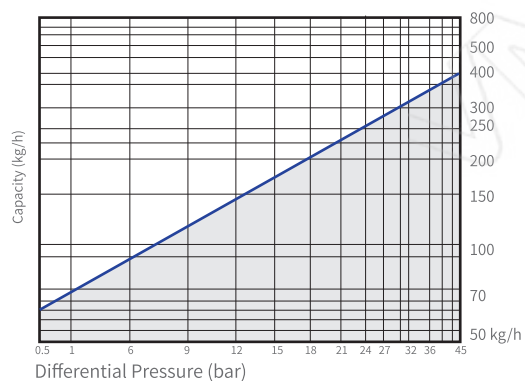

Technical Parameter

Nominal pressure	PN25
Max. allowable pressure (Shell)	2.45MPa/200°C
Max. allowable temperature (Shell)	450°C/1.03MPa
Factory steam action test	>3 times/1.6MPa
Max. operating pressure	1.6MPa
Max. operating temperature	350°C
Factory cold test pressure	3.8MPa
Air test	2.0MPa

Material List

- Bonnet : WCB/F304/F316
- Disc: Martensitic stainless steel
- Body : WCB/CF8/CF8M
- Other internal parts: Austenitic stainless steel
- Seat : Martensitic stainless steel

SBT30 Capacity Chart

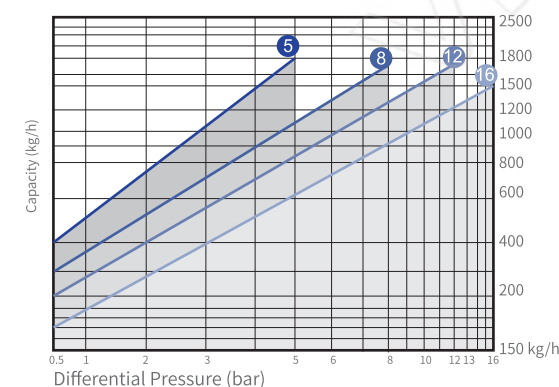

working Principle

- Relying on the difference in vapor and liquid density.

Features

- The body and cover are all made of cast steel.
- All internal parts are made of stainless steel, and the movable parts are fully designed Considering the wear allowance, the service life of the steam trap is improved.
- U-shaped flow channel design, to achieve water sealing effect, no leakage of steam.
- Reliable flexible closure system with patented technology, no steam leakage.
- Install anti-water hammer device.
- Built-in check valve, suitable for superheated steam environment.
- Built-in filter allows the steam trap to work in a clean environment.
- Select different displacement curves according to the pressure.
- The back pressure rate is as high as 90% or more.
- After the steam is stopped, the condensed water can be removed by opening the screw plug to prevent damage to the trap due to low temperature freezing.

Technical Standard

- GB/T12250-2005 Steam Traps Terminology Marking Structure Length
 - GB/T22654-2008 Technical Conditions for Steam Traps
 - GB/T12251-2005 Test Method for Steam Traps
 - ISO 6948 Automatic steam traps
- Production and performance characteristic tests

Structure Diagram

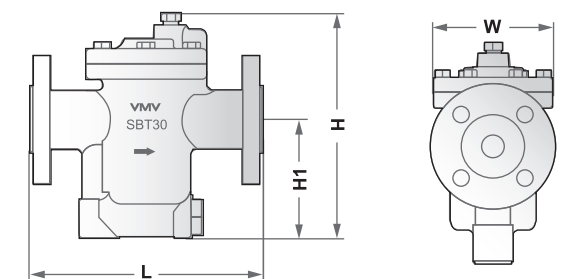

Structural Dimension Table

Model	Size	L	H	H1	W	Weight
SBT30T	DN25-32	210	320	187	174	15Kg
SBT30W	DN25-32	210	320	187	174	15Kg
SBT30F	DN25-50	270	320	187	174	19.5Kg

Inverted Bucket Steam Trap

Inverted Bucket Steam Trap

SBT11A Inverted Bucket Steam Trap

Inverted Bucket Steam Trap Station SBT11TVS



Working Principle

- Relying on the difference in vapor and liquid density.

Features

- The body and cover are all made of stainless steel.
- All internal parts are made of stainless steel, and the wear allowance has been fully considered in the design of moving parts, which improves the service life of the steam trap
- Internally installed U-shaped stainless steel pipe flow channel design to achieve water sealing effect.
- Reliable flexible closure system with patented technology, no steam leakage.
- External filter connector, so that the trap works in a clean environment.
- The back pressure rate is as high as 90% or more.

Technical Standard

- GB/T12250-2005 Steam Traps Terminology Marking Structure Length
 - GB/T22654-2008 Technical Conditions for Steam Traps
 - GB/T12251-2005 Test Method for Steam Traps
 - ISO 6948 Automatic steam traps
- Production and performance characteristic tests

Flow Chart



Structure Diagram

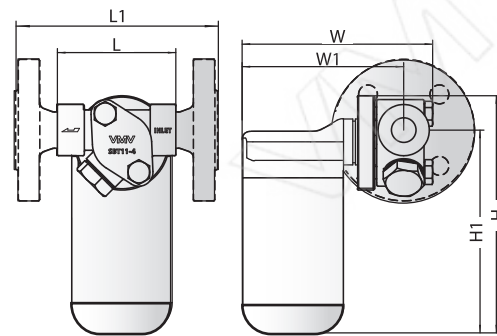

Structural Dimension Table

Model	Size	L	L1	W	W1	H	H1
SBT11A	DN15-25	88	210	152	130	176	150

Weight

SBT11A: 4.2Kg
SBT11AF: 6.1Kg

Technical Parameter

Nominal pressure	PN25
Max. allowable pressure (Shell)	1.89Mpa/50°C
Max. allowable temperature (Shell)	350°C/1.62MPa
Factory steam action test	>3 times/1.6MPa
Max. working pressure	1.6MPa
Max. operating temperature	350°C
Factory cold test pressure	3.8MPa
Air test	0.6MPa

Material List

Bonnet : F304/F316 Disc: Martensitic stainless steel
Body : F304/F316 Other internal parts:
Seat : Martensitic Austenitic stainless steel
 stainless steel

SBT11A Capacity Chart

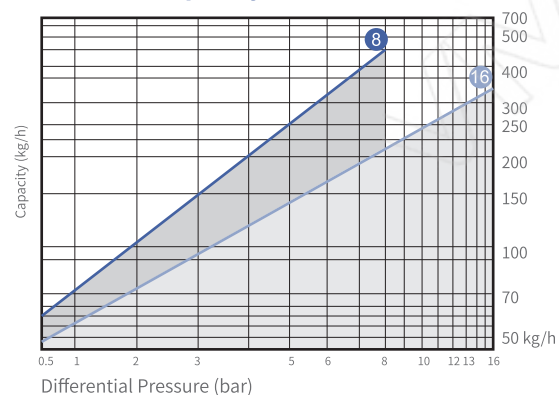

Working Principle

- Relying on the difference in vapor and liquid density.

Features

- The body and cover are all made of stainless steel.
- All internal parts are made of stainless steel, and the wear allowance has been fully considered in the design of moveable parts, which improves the service life of the steam trap
- Internally installed U-shaped stainless steel pipe flow channel design to achieve water sealing effect.
- External filter connector, so that the steam trap works in a clean environment.
- The back pressure rate is as high as 90% or more.

Technical Standard

- GB/T12250-2005 Steam Traps Terminology Marking Structure Length
 - GB/T22654-2008 Technical Conditions for Steam Traps
 - GB/T12251-2005 Test Method for Steam Traps
 - ISO 6948 Automatic steam traps
- Production and performance characteristic tests

Flow Chart

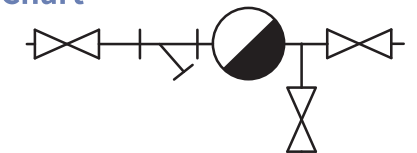

Structure Diagram

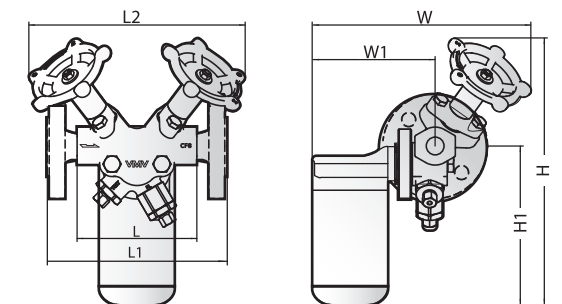

Structural Dimension Table

Model	Size	L	L1	L2	W	W1	H	H1
SBT11TVS	DN15-25	90	200	220	230	132	266	160

Weight

SBT11TVS: 5.4Kg
SBT11TVSF: 7.6Kg

Technical Parameter

Nominal pressure	PN25
Max. allowable pressure (Shell)	1.89Mpa/50°C
Max. allowable temperature (Shell)	350°C/1.62MPa
Factory steam action test	>3 times/1.6MPa
Max. working pressure	1.6MPa
Max. operating temperature	350°C
Factory cold test pressure	3.8MPa
Air test	0.6MPa

Material List

Bonnet : F304/F316 Disc: Martensitic stainless steel
Body : F304/F316 Other internal parts:
Seat : Martensitic Austenitic stainless steel
 stainless steel

SBT11TVS Capacity Chart

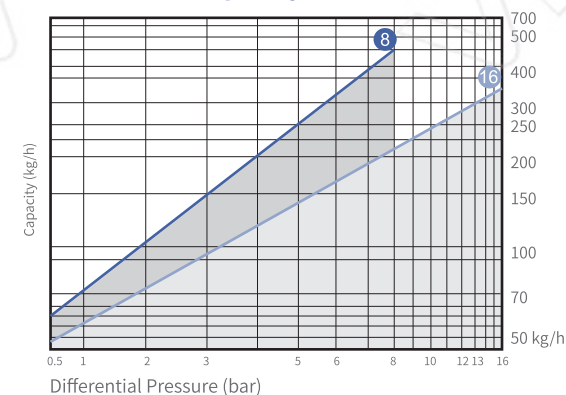

Pilot Inverted Bucket Steam Trap

Pilot Inverted Bucket Steam Trap

The pilot inverted bucket steam trap has the characteristics of large displacement, long life, good energy saving effect, water hammer resistance, and beautiful appearance. It is widely used in process heat tracing, jacketed heating kettles tank, reboilers and other equipment.

The technical advantages of VMV traps are: unique and reasonable structure, high-precision internal parts.

High Corrosion Resistance

Using WCB material
Fully consider corrosion allowance, minimum shell wall thickness, pressure and temperature grade when designing

Flexible Pilot Closure System

High-precision flexible pilot closing system Pilot valve guides the main valve to open and close

Stainless Steel Bucket Exhaust Structure

Small holes are left on the upper part of the bucket to remove air and other non-condensable gases to prevent the occurrence of steam lock the valve

Built-in Check Valve

Prevents water hammer from damaging internals
Also suitable for superheated steam environment

Built-in Filter

Effectively prevent pipeline impurities from entering the valve
Make sure the trap valve is working properly

Leak-free Structure Design

The U-shaped flow channel design ensures that the inside of the valve body is in a water-sealed state
No raw steam leakage

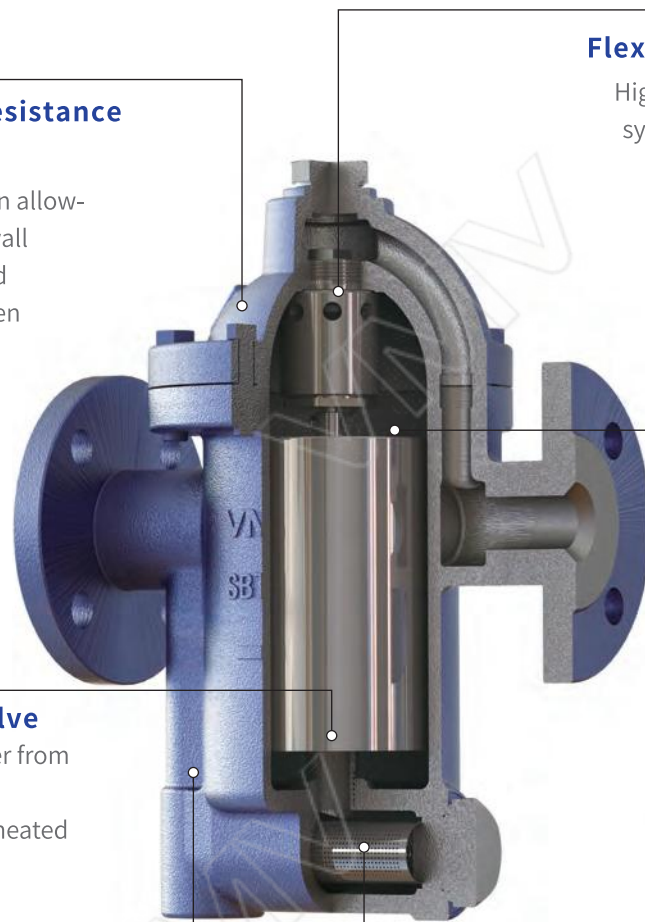

Structural features

In the design of VMV steam trap, take full account of the strength of the shell, the pressure and temperature grade, the manufacturability of casting, the tightness of the valve core and seat closure, the impact caused by the mixing of water and steam, and the strength of the valve cover gasket are affected by the low temperature environment, etc. Pilot inverted bucket steam traps work on the difference in density between steam and condensate. When the bucket is full of condensed water and non-condensable gas, the exhaust hole on the upper part of the bucket removes the non-condensable gas, the bucket loses buoyancy and drives the pilot valve core to move down to the bottom dead position, guiding the main valve to open, and steam enters the bucket after the trap is drained, the bucket floats to drive the pilot valve and the main valve to move up to close the trap. The biggest advantages of pilot inverted bucket traps are small size, large capacity, high back pressure rate, long life, reliable action, convenient maintenance, and no original steam leakage.

WCB/A105 Material PN25

Valve Body Pressure-Temperature Ratings

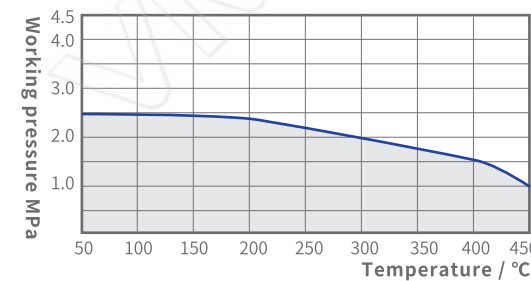

WCB/A105 Material PN40

Valve Body Pressure-Temperature Ratings

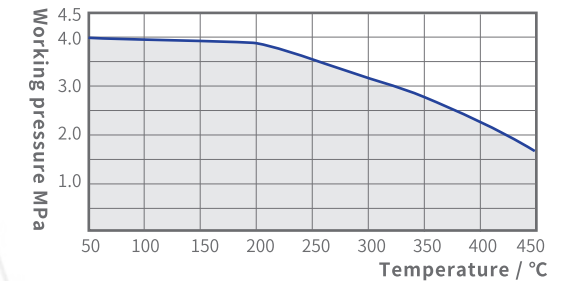

Selection and Installation of Pilot Inverted Bucket Steam Traps

The pilot inverted bucket steam trap is intermittently drained, with a subcooling degree of 5-10°C and a back pressure rate of more than 85% (back-end pipeline pressure/steam pressure). In general, the safety factor is 2-3 times when selecting, and 5-8 times for air separation units and drying cylinders.

The amount of condensed water and the differential pressure of the steam-using equipment are important indicators for model selection. For the same type of steam trap, the displacement increases with the increase of the differential pressure. See the details on displacement curve. Special reminder: Please do not mistakenly think that a trap with a large diameter has a large displacement. The pilot inverted bucket trap is installed horizontally at the bottom of the pipeline or equipment. The basic configuration of the trap is shown in the figure on the right.

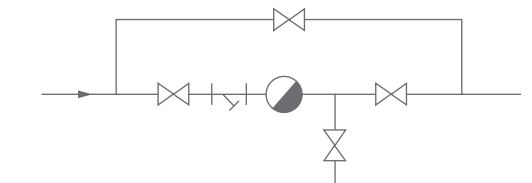

In order to prevent the water hammer phenomenon after the water vapor in the pipeline is mixed, a check valve must be built in.

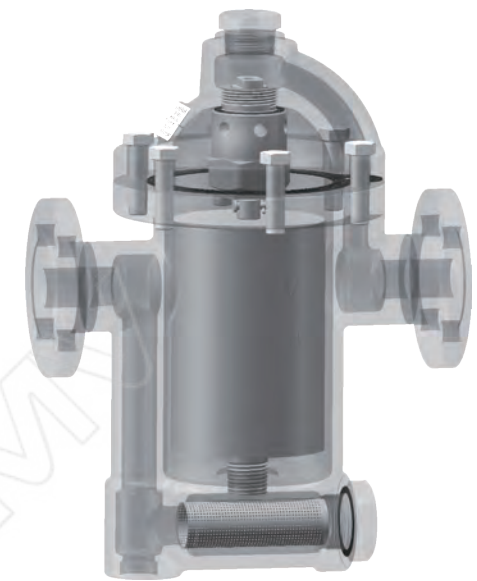

Pilot Inverted Bucket Steam Trap

Pilot Inverted Bucket Steam Trap

SBT40 Pilot Inverted Bucket Steam Trap

Pilot Inverted Bucket Steam Trap SBT50



Working Principle

•Relying on the difference of vapor and liquid density, the main valve is guided to open through the pilot valve, and the displacement is large.

Features

- The body and cover are made of cast steel.
- The internal parts are all made of stainless steel, and the wear allowance has been fully considered in the design of the movable parts, which improves the service life of the trap.
- U-shaped runner design achieves water sealing effect without leakage of steam.
- Flexible closing system with patented technology, no steam leakage.
- Install anti-water shock device, so that the fluid entering the valve body does not produce water hammer phenomenon.
- Built-in check valve, suitable for superheated steam environment.
- Built-in filter allows the steam trap to work in a clean environment.
- Select different displacement curves according to the pressure.
- The back pressure rate is as high as 90% or more.
- After stopping, the screw plug can be opened to drain the condensed water to prevent damage to the trap due to low temperature freezing.

Technical Standard

- GB/T12250-2005 Steam Traps Terminology Marking Structure Length
- GB/T22654-2008 Technical Conditions for Steam Traps
- GB/T12251-2005 Test Method for Steam Traps
- ISO 6948 Automatic steam traps

Production and performance characteristic tests

Structure Diagram

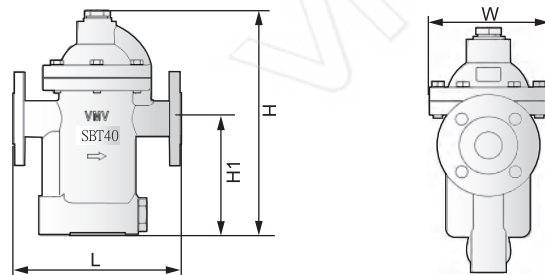

Dimension Table

Model	Size	Unit(mm)					Weight
		L	H	H1	W		
SBT40T	DN25-32	210	360	187	174	16.5Kg	
SBT40W	DN25-32	210	360	187	174	16.5Kg	
SBT40F	DN25-50	270	360	187	174	21Kg	

Technical Parameter

Nominal pressure	PN25
Max. allowable pressure (Shell)	2.45MPa/200°C
Max. allowable temperature (Shell)	450°C/1.03MPa
Factory steam action test	>3 times/1.6MPa
Max. working pressure	1.6MPa
Max. operating temperature	350°C
Factory cold test pressure	3.8MPa
Air test	2.0MPa

Material List

Bonnet: WCB/CF8/CF8M Disc: Martensitic Stainless Steel
 Body: WCB/CF8/CF8M Other internal parts:
 Seat: Martensitic Austenitic Stainless Steel
 Stainless Steel

SBT40 Capacity Chart

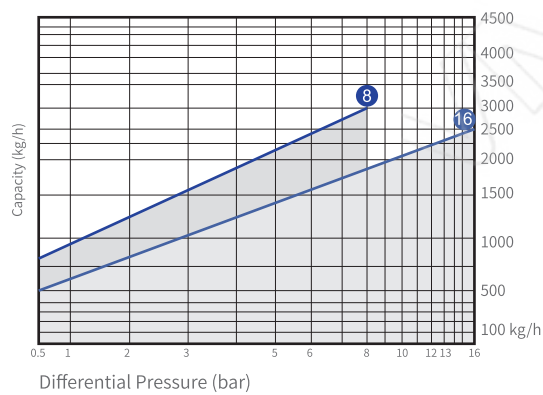

Working Principle

•Relying on the difference of vapor and liquid density, the main valve is guided to open through the pilot valve, and the displacement is large.

Features

- The body and cover are made of cast steel.
- The internal parts are all made of stainless steel, and the wear allowance has been fully considered in the design of the movable parts, which improves the service life of the steam trap.
- U-shaped runner design achieves water sealing effect without leakage of steam.
- Flexible closing system with patented technology, no steam leakage.
- Install anti-water shock device, so that the fluid entering the body does not produce water hammer phenomenon.
- Built-in check valve, suitable for superheated steam environment.
- Built-in filter allows the steamtrap to work in a clean environment.
- Select different displacement curves according to the pressure.
- The back pressure rate is as high as 90% or more.
- After stopping, the screw plug can be opened to drain the condensed water to prevent damage to the steam trap due to low temperature freezing.

Technical Standard

- GB/T12250-2005 Steam Traps Terminology Marking Structure Length
- GB/T22654-2008 Technical Conditions for Steam Traps
- GB/T12251-2005 Test Method for Steam Traps
- ISO 6948 Automatic steam traps

Production and performance characteristic tests

Structure Diagram

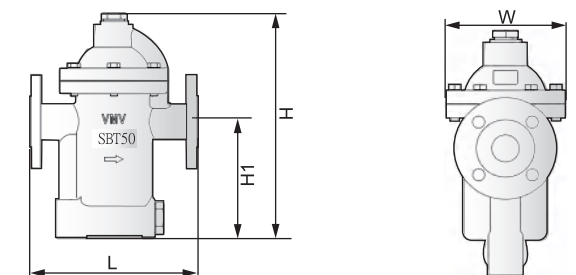

Dimension Table

Model	Size	Unit(mm)					Weight
		L	H	H1	W		
SBT50W	DN25-32	260	410	210	220	27.5Kg	
SBT50F	DN25-50	320	410	210	220	33Kg	

Technical parameter

Nominal pressure	PN25
Max. allowable pressure (Shell)	2.45MPa/200°C
Max. allowable temperature (Shell)	450°C/1.03MPa
Factory steam action test	>3 times/1.6MPa
Max. working pressure	1.6MPa
Max. operating temperature	350°C
Factory cold test pressure	3.8MPa
Air test	2.0MPa

Material List

Bonnet: WCB/CF8/CF8M Disc: Martensitic Stainless Steel
 Body: WCB/CF8/CF8M Other internal parts:
 Seat: Martensitic Austenitic Stainless Steel
 Stainless Steel

SBT50 Capacity Chart

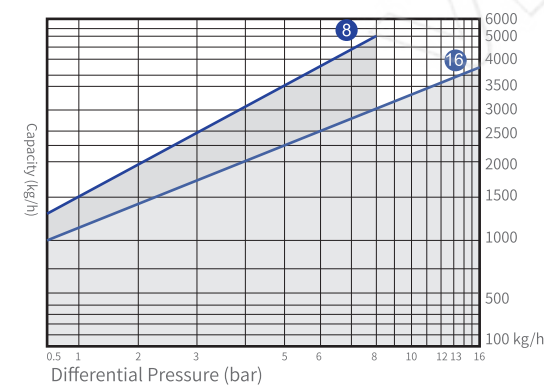

Pilot Inverted Bucket Steam Trap

Pilot Inverted Bucket Steam Trap

SBT60 Pilot Inverted Bucket Steam Trap

Pilot Inverted Bucket Steam Trap SBT63



Working Principle

•Relying on the difference of vapor and liquid density, the main valve is guided to open through the pilot valve, and the displacement is large.

Features

- The body and cover are made of cast steel.
- The internal parts are all made of stainless steel, and the wear allowance has been fully considered in the design of the movable parts, which improves the service life of the steamtrap.
- U-shaped runner design achieves water sealing effect without leakage of steam.
- Flexible closing system with patented technology, no steam leakage.
- Install anti-water shock device, so that the fluid entering the valve body does not produce water hammer phenomenon.
- Built-in check valve, suitable for superheated steam environment.
- Built-in filter allows the steam trap to work in a clean environment.
- Select different displacement curves according to the pressure.
- The back pressure rate is as high as 90% or more.
- After stopping, the screw plug can be opened to drain the condensed water to prevent damage to the trap due to low temperature freezing.

Technical Standard

- GB/T12250-2005 Steam Traps Terminology Marking Structure Length
- GB/T22654-2008 Technical Conditions for Steam Traps
- GB/T12251-2005 Test Method for Steam Traps
- ISO 6948 Automatic steam traps
Production and performance characteristic tests

Structure Diagram

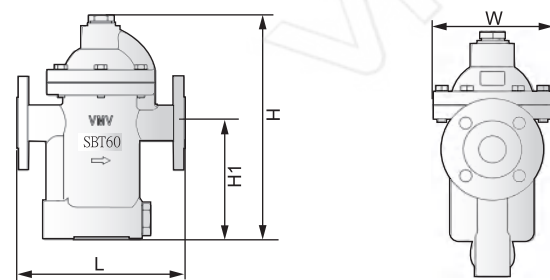

Dimension Table

Model	Size	L	H	H1	W	Weight
SBT60W	DN25-32	260	460	260	220	27.5Kg
SBT60F	DN25-50	320	460	260	220	36Kg

Technical Parameter

Nominal pressure	PN25
Max. allowable pressure (Shell)	2.45MPa/200°C
Max. allowable temperature (Shell)	450°C/1.03MPa
Factory steam action test	>3 times/1.6MPa
Max. working pressure	1.6MPa
Max. operating temperature	350°C
Factory cold test pressure	3.8MPa
Air test	2.0MPa

Material List

Bonnet: WCB/CF8/CF8M Disc: Martensitic Stainless Steel
 Body: WCB/CF8/CF8M Other internal parts:
 Seat: Martensitic Austenitic Stainless Steel
 Stainless Steel

SBT60 Capacity Chart

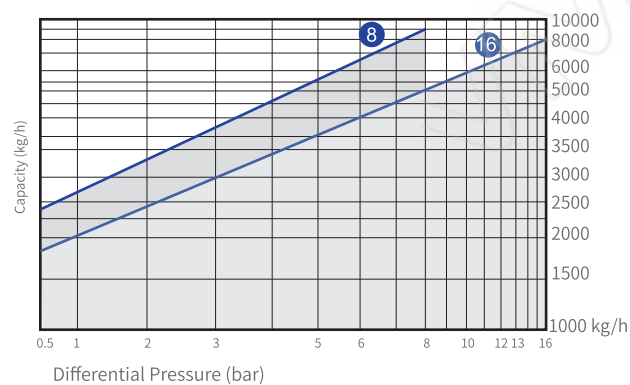

Working Principle

•Relying on the difference of vapor and liquid density, the main valve is guided to open through the pilot valve, and the displacement is large.

Features

- The body and cover are made of cast steel.
- The internal parts are all made of stainless steel, and the wear allowance has been fully considered in the design of the movable parts, which improves the service life of the trap.
- U-shaped flow channel design achieves water sealing effect without leakage of steam.
- Flexible closing system with patented technology, no steam leakage.
- Install anti-water shock device, so that the fluid entering the body does not produce water hammer phenomenon.
- Built-in check valve, suitable for superheated steam environment.
- Built-in filter allows the steam trap to work in a clean environment.
- Select different displacement curves according to the pressure.
- The back pressure rate is as high as 90% or more.
- After stopping, the screw plug can be opened to drain the condensed water to prevent damage to the steam trap due to low temperature freezing.

Technical Standard

- GB/T12250-2005 Steam Traps Terminology Marking Structure Length
- GB/T22654-2008 Technical Conditions for Steam Traps
- GB/T12251-2005 Test Method for Steam Traps
- ISO 6948 Automatic steam traps
Production and performance characteristic tests

Structure Diagram

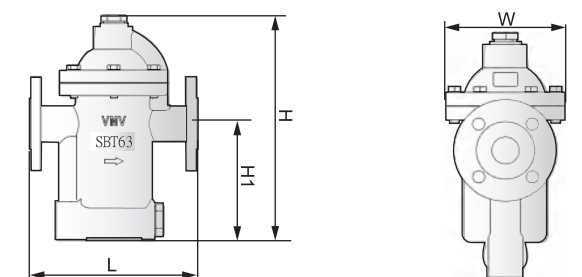

Dimension Table

Model	Size	L	H	H1	W	Weight
SBT63W	DN25-32	260	460	260	220	27.5Kg
SBT63F	DN25-50	320	460	260	220	36Kg

Technical Parameter

Nominal pressure	PN40
Max. allowable pressure (Shell)	3.92MPa/200°C
Max. allowable temperature (Shell)	450°C/1.66MPa
Factory steam action test	>3 times/1.6MPa
Max. working pressure	3.2MPa
Max. operating temperature	350°C
Factory cold test pressure	6.0MPa
Air test	2.0MPa

Material List

Bonnet: WCB/CF8/CF8M Disc: Martensitic Stainless Steel
 Body: WCB/CF8/CF8M Other internal parts:
 Seat: Martensitic Austenitic Stainless Steel
 Stainless Steel

SBT63 Capacity Chart

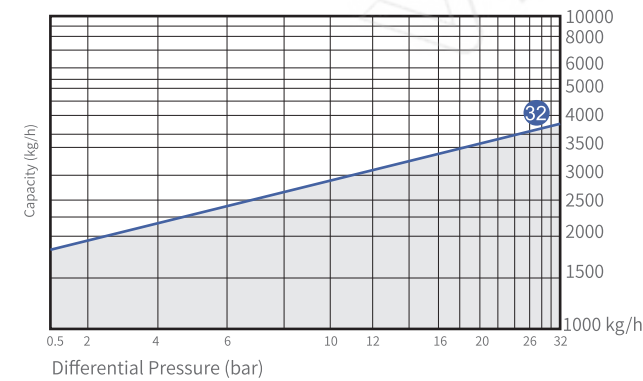

Lever Ball Float Steam Trap

Lever Ball Float Steam Trap

The lever ball float steam trap has the characteristics of large displacement, long life, good energy saving effect, water hammer resistance, beautiful appearance, etc. It is widely used in process heat tracing, jacketed heating kettles tank, reboilers and other equipment.

The technical advantages of VMV steam traps are: unique and reasonable structure, high-precision internal parts.

High Corrosion Resistance

Using WCB material
Fully consider corrosion allowance, minimum shell wall thickness, pressure and temperature grade when designing

Unique Exhaust Air Valve

The unique air exhaust valve makes the trap no air blocking phenomenon caused by air and other non-condensable gases during initial or normal operation.

Flexible Closing System

Unique flexible closing mechanism
No rigid impact to ensure long life
Micron-level high-precision valve seat. The valve core ensures reliable and tight closing

Built-in Filter

Effectively prevent pipeline impurities from entering the valve
Keeps traps working properly while preventing water hammer from damaging internal components

Stainless Steel Float

Defect-free laser-welded float ensures long service life of the trap

Unique Float Assembly

Precisely calculated structure of the floating ball assembly enables the closing system to work in a water-sealed state without steam leakage

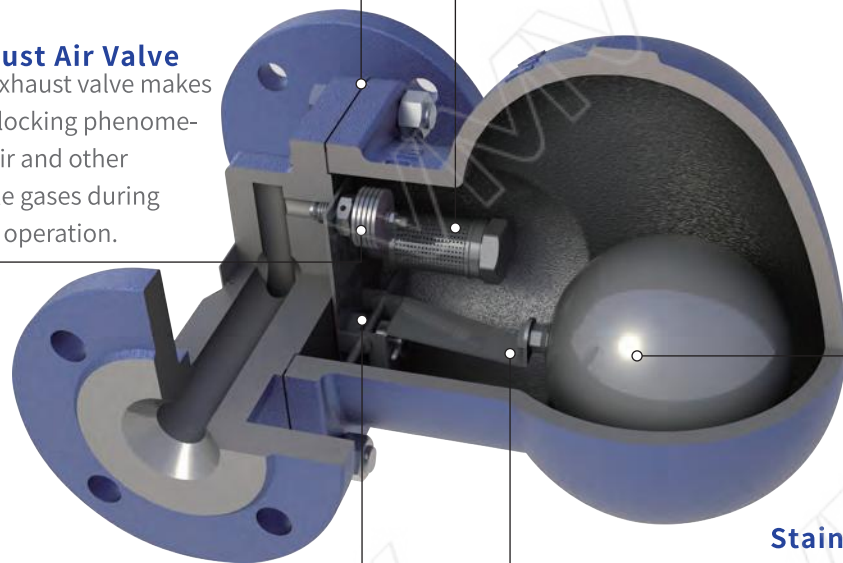

Structural Features

The flexible closing system is applied to the lever ball float trap, which solves the problems of short life and lax closing. In the design, the strength of the shell, the pressure and temperature grade, the manufacturability of casting, the impact caused by the fluid flow channel and the water-vapor mixing are considered, and the closed system works in a water-sealed state.

Lever ball float steam trap works on the difference in density between steam and condensate. When the valve body is filled with condensed water and non-condensable gas, the air exhaust valve is opened to remove the non-condensable gas, the floating ball moves up to drive the valve core to open, and after the condensate is drained, the floating ball drives the valve core to move down and closes the trap.

The biggest advantage of lever ball float trap is high back pressure rate (differential pressure 0.01bar can work), long life, reliable action, easy maintenance and no original steam

WCB/A105 Material PN25

Valve Body Pressure-Temperature Ratings

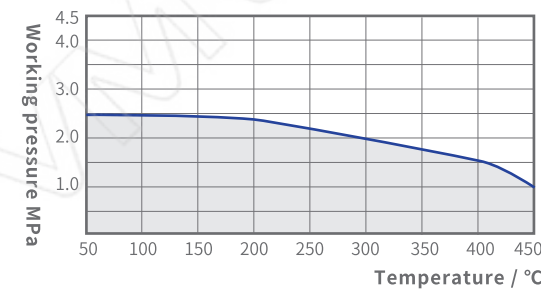

Lever Ball Float Trap

The lever ball float type steam trap is for continuous drainage, the subcooling degree is about 5°C, and the back pressure rate is over 95% (back-end pipeline pressure/steam pressure). In general, the safety factor is 2-3 times when selecting, and 5-8 times for air separation units and drying cylinders. Condensate volume and differential pressure of steam-using equipment are important indicators for model selection. The same type of trap increases with the increase of pressure difference and displacement. See the details on displacement curve.

Special reminder: Please do not mistakenly think that a trap with a large diameter has a large displacement. The lever ball float trap is installed horizontally at the bottom of the pipeline or equipment, and the SFT10 trap can be installed horizontally or vertically. The basic configuration is shown in the figure on the right.

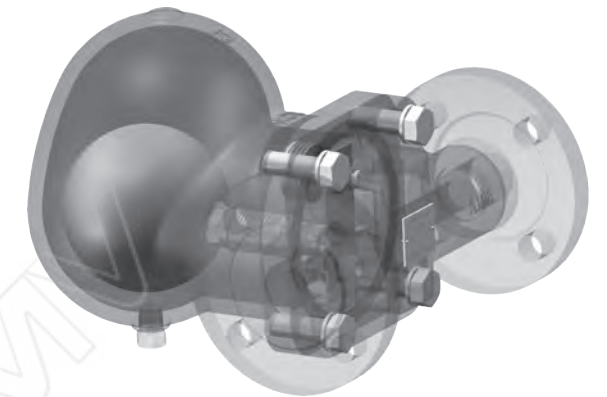

The lever ball float type steam trap is made of ASTM216 WCB/WC6 /CF8/ CF8M stainless steel, some bonnets are made of ASTM A105/F304/F316, the inner parts are made of stainless steel, and there is a built-in filter device.

- Nominal pressure: PN25;
- Max allowable temperature: 425°C;
- Max working pressure: 1.6MPa /2.0MPa /3.2MPa /4.5MPa/6.5MPa;
- Max operating temperature: 400°C;
- Connection type: threaded RC or flange (GB/T9124.1-2019; HG/T20615-2009; HG/T20592-2009, etc.)

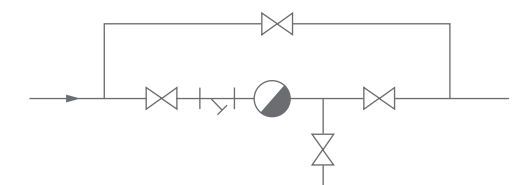

Lever ball float traps are best suited for back pressure recovery of condensate.

Lever Ball Float Proportional Regulating Steam Trap

Lever Ball Float Proportional Regulating Steam Trap

Lever ball float proportional regulating steam trap is characterized by change according to condensate discharge rate large proportional displacement, long life, good energy-saving effects, water hammer resistance, and beautiful appearance. It is widely used in process heat tracing, jacket heating kettles, reboilers and other equipment.

The technical advantages of VMV steam traps are: unique and reasonable structure and high-precision internals!

Unique Float Assembly

Precisely calculated floating ball component structure makes the closing system work under water seal without steam leakage. Laser welded float ensures long life of steam trap.

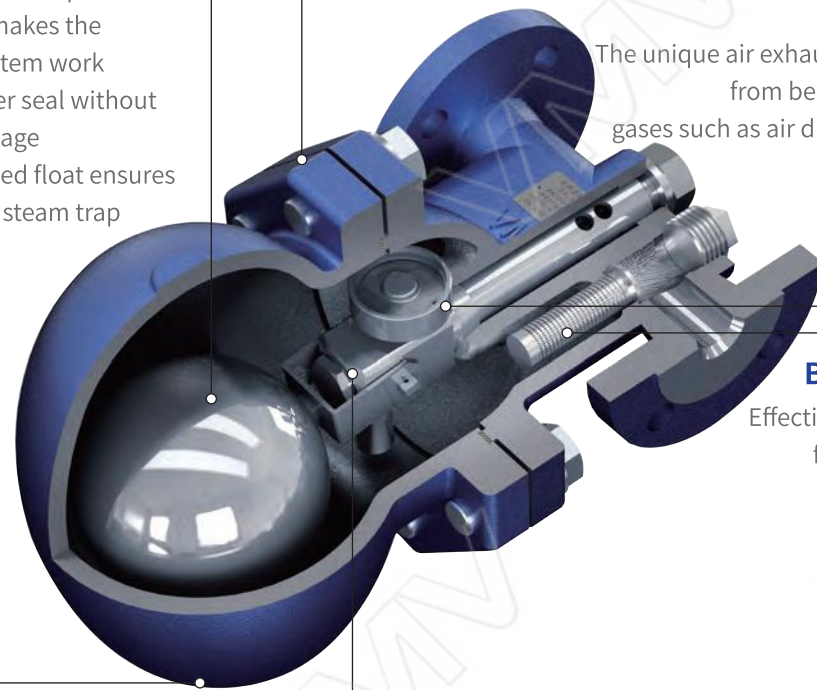

High Corrosion Resistance

Using WCB material, full consideration of corrosion allowance, minimum shell wall thickness, pressure and temperature rating.

Unique Exhaust Valve

The unique air exhaust valve prevents the steam trap from being blocked by non-condensable gases such as air during initial or normal operation.

Built-in Filtering Device

Effectively prevents pipeline impurities from entering the valve to ensure the proper operation of the trap.

Precise and Reliable Controller

The controller adopts a rotating shaft structure, long life without rigid impact. Valve core ensures the reliability of the closing system and no steam leakage.

Reserved the sewage outlet to regularly discharge the dirt

Structural Features

VMV applied the rotary shaft controller to lever ball float proportional regulating steam trap, which solved the problems of short life and lax closing. In the design, factors such as shell strength, pressure and temperature grade, casting process-ability, fluid flow path, impact caused by water and vapor mixing, losing the secondary water seal valve, the strength of the cover pad affected by low temperature environment and other factors are fully considered.

Lever ball float proportional regulating steam trap relies on the density difference between steam and condensate to work. When the valve body is full of condensed water and non-condensable gas, the air exhaust valve is opened to remove the non-condensable gas, proportional enlarged valve seat hole until it is fully opened, and the floating ball moves up to drive the controller spool rotation. After draining the condensed water, the floating ball drives the controller spool to rotate and adjust the size of the valve seat hole until closing.

WCB/A105 Material PN40

Valve Body Pressure - Rating Temperature

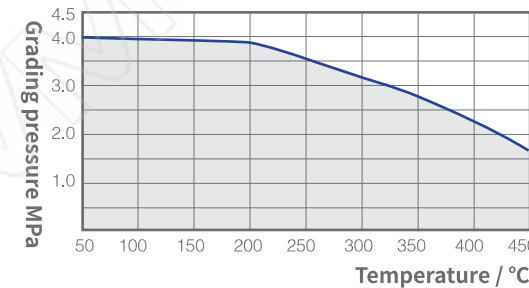

Lever Ball Float Proportional Regulating Steam Trap Selection and Installation

The lever ball float steam trap can drain water continuously. The subcooling degree is about 5°C, and the back pressure rate is above 95% (back-end pipeline pressure/steam pressure). It is suitable for pipelines and small equipment to remove condensate and back pressure to recover condensate. Generally, the safety factor is 2-3 times when selecting models, and 5-8 times for air separation units and drying cylinders. The condensed water volume and pressure difference of steam equipment are important indicators for type selection. The displacement of the same type of trap increases with the increase of pressure difference. Check the displacement curve in detail.

Notice: Please don't mistake it for a large-diameter steam trap with a large displacement.

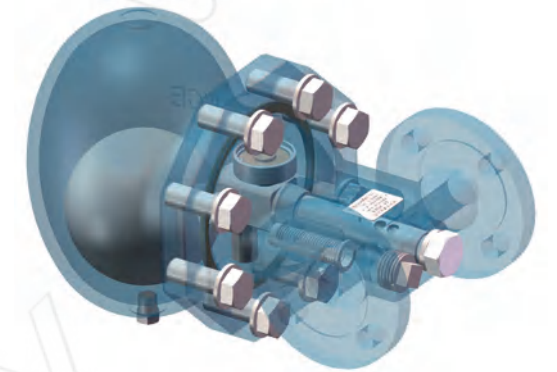

The biggest advantage of lever ball float proportional regulating steam trap is suitable for a variety of displacement variables from small to large working environment, in addition to high back pressure rate (it can work under the pressure difference of 0.01bar), long life, reliable operation, convenient maintenance, with no original steam leakage.

The lever ball float proportional regulating steam trap is made of ASTM216 WCB cast steel, part of the valve cover is made of ASTM A105, the internals are made of stainless steel, with built-in filter.

- Nominal pressure: PN40;
- Max allowable temperature: 425°C;
- Max working pressure: 3.2MPa;
- Max working temperature: 350°C;
- Connection method: threaded RC or flange (GB/T9115.1-2000; HG/T20615-2009; HG/T20592-2009, etc.)

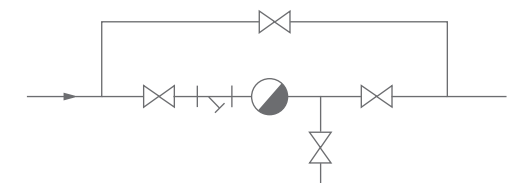

The lever ball float proportional regulating steam trap is installed horizontally at the bottom of the pipeline or equipment. The basic configuration is shown on the graph.

The lever ball float proportional regulating steam trap is most suitable for back pressure recovery of condensate.

Lever Ball Float Steam Trap

Lever Ball Float Steam Trap

SFT10 Lever Ball Float Steam Trap

Lever Ball Float Steam Trap SFT10A

Working Principle

- Based on the density of vapor and liquid.

Features

- The body and are made of cast steel/forged steel.
- All internal parts are made of stainless steel, and the wear allowance has been fully considered in the design of movable parts, which improves the service life of the steam trap.
- Special flow channel design to achieve zero water hammer.
- Patented flexible closing system and micron-level precision closing system double guarantee no steam leakage and long service life.
- Built-in air exhaust valve to prevent air lock.
- The independent filter makes the trap work in a clean environment.
- Choose different displacement curves according to the pressure.
- The back pressure rate is as high as 95%

Technical Standard

- GB/T12250-2005 Steam Traps Terminology Marking Structure Length
- GB/T22654-2008 Technical Conditions for Steam Traps
- GB/T12251-2005 Test Method for Steam Traps
- ISO 6948 Automatic steam traps Production and performance characteristic tests

Structure Diagram

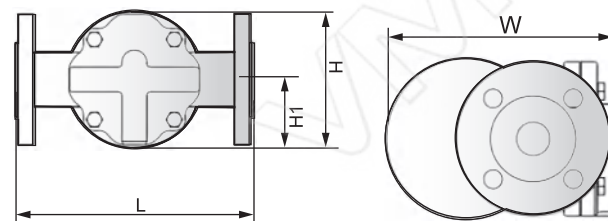

Dimension Table

Unit(mm)						
Model	Size	L	H	H1	W	Weight
SFT10T	DN15-25	150	120	60	170	5.5 Kg
SFT10W	DN15-25	150	120	60	170	5.5 Kg
SFT10F	DN15-25	210	120	60	170	8 Kg



Technical Parameters

Nominal pressure	PN40
Max. allowable pressure (Shell)	3.92MPa/200°C
Max. allowable temperature (Shell)	450°C/1.66MPa
Factory steam action test	>3 times/1.6MPa
Max. working pressure	3.2MPa
Max. operating temperature	350°C
Factory cold test pressure	6.0MPa
Air test	2.0MPa

Material List

- Bonnet: A105/F304/F316
- Body: WCB/CF8/CF8M
- Seat: Martensitic Stainless Steel
- Disc: Austenitic Stainless Steel
- Other Internal Parts: Austenitic Stainless Steel

SFT10A Capacity Chart

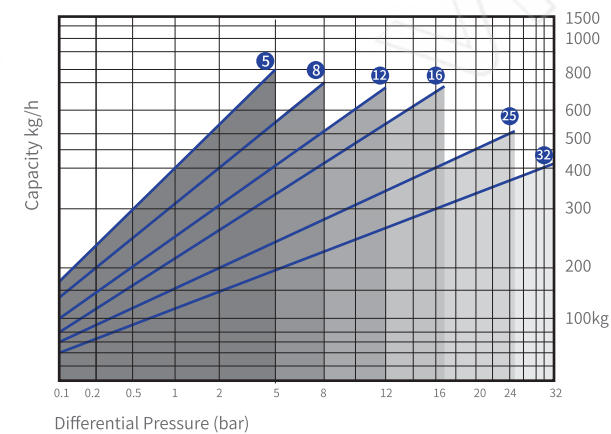

Working Principle

- Based on the density of vapor and liquid.

Features

- The valve body and bonnet are made of cast steel/forged steel.
- All internal parts are made of stainless steel, and the wear allowance has been fully considered in the design of movable parts, which improves the service life of the steam trap.
- Special flow channel design to achieve zero water hammer.
- Patented flexible closing system and micron-level precision closing system double guarantee no steam leakage and long service life.
- Built-in air exhaust valve to prevent steam lock.
- The independent filter makes the trap work in a clean environment.
- Choose different capacity chart according to the pressure.
- The back pressure rate is as high as 95%
- The drain plug is designed at the bottom of the trap to ensure that the internal water is removed after stopping, to prevented floating ball from freezing in cold weather.

Technical Standard

- GB/T12250-2005 Steam Traps Terminology Marking Structure Length
- GB/T22654-2008 Technical Conditions for Steam Traps
- GB/T12251-2005 Test Method for Steam Traps
- ISO 6948 Automatic steam traps Production and performance characteristic tests

Structure Diagram

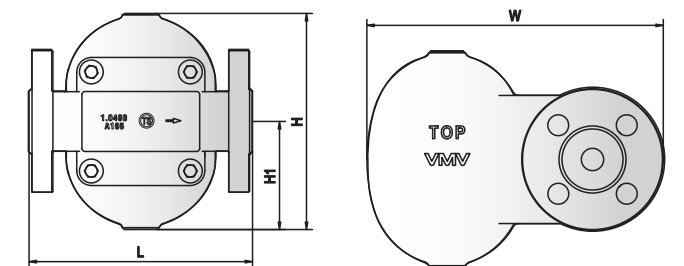

Dimension Table

Unit(mm)						
Model	Size	L	H	H1	W	Weight
SFT10AT	DN15-20	120	145	73	172	5.0 kg
	DN25	145	145	73	180	5.7 kg
SFT10AW	DN15-20	120	145	73	172	5.0 kg
	DN25	145	145	73	180	5.7 kg
SFT10AF	DN15-20	150	145	73	205	7.0 kg
	DN25	160	145	73	213	8.1 kg

Technical Parameters

Nominal pressure	PN25
Max. allowable pressure (Shell)	2.45MPa/200°C
Max. allowable temperature (Shell)	450°C/1.03MPa
Factory steam action test	>3 times/1.6MPa
Max. working pressure	1.6MPa
Max. operating temperature	350°C
Factory cold test pressure	3.8MPa
Air test	2.0MPa

Material List

- Bonnet: A105/F304/F316
- Body: WCB/CF8/CF8M
- Seat: Martensitic Stainless Steel
- Disc: Martensitic Stainless Steel
- Other Internal Parts: Austenitic Stainless Steel

SFT10 Capacity Chart

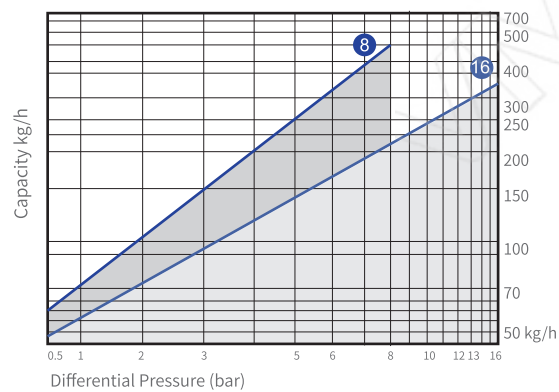

Lever Ball Float Steam Trap

Lever Ball Float Steam Trap

SFT20A Lever Ball Float Steam Trap

Lever Ball Float Steam Trap SFT30A

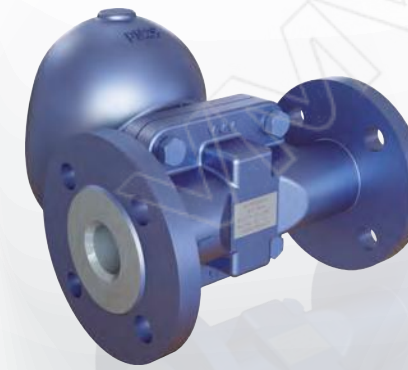

Working Principle

- Based on the density of vapor and liquid.

Features

- The body and bonnet are made of cast steel/forged steel.
- All internal parts are made of stainless steel, and the wear allowance has been fully considered in the design of movable parts, which improves the service life of the steam trap.
- Special flow channel design achieves zero water hammer.
- Patented flexible closing system and micron-level precision closing system double guarantee no steam leakage and long service life.
- Built-in air exhaust valve to prevent air lock.
- The independent filter makes the trap work in a clean environment.
- Choose different capacity chart according to the pressure.
- The back pressure rate is as high as 95%
- The drain plug is designed at the bottom of the trap to ensure that the internal water will be removed, to prevent floating ball from freezing in cold weather.

Technical Standard

- GB/T12250-2005 Steam Traps Terminology Marking
- GB/T22654-2008 Technical Conditions for Steam Traps
- GB/T12251-2005 Test Method for Steam Traps
- ISO 6948 Automatic steam traps

Production and performance characteristic tests

Structure Diagram

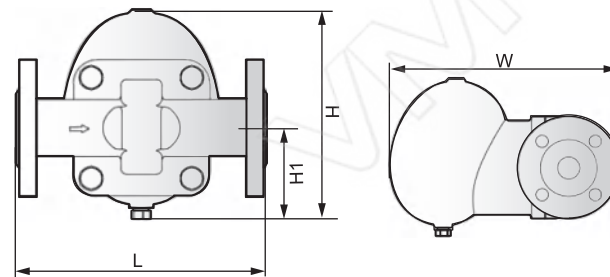

Dimension Table

Model	Size	L	H	H1	W	Weight
SFT20AT	DN15-25	150	175	75	227	8.5 kg
SFT20AW	DN15-25	150	175	75	227	8.5 kg
SFT20AF	DN15-25	210	175	75	260	11 kg

Technical Parameters

Nominal pressure	PN25
Max. allowable pressure (Shell)	2.45MPa/200°C
Max. allowable temperature (Shell)	450°C/1.03MPa
Factory steam action test	>3 times/1.6MPa
Max. working pressure	1.6MPa
Max. operating temperature	350°C
Factory cold test pressure	3.8MPa
Air test	2.0MPa

Material List

Bonnet: A105/F304/F316 Disc: Martensitic Stainless Steel
 Body: WCB/CF8/CF8M Other Internal Parts:
 Seat: Martensitic Stainless Steel Austenitic Stainless Steel

SFT20A Capacity Chart

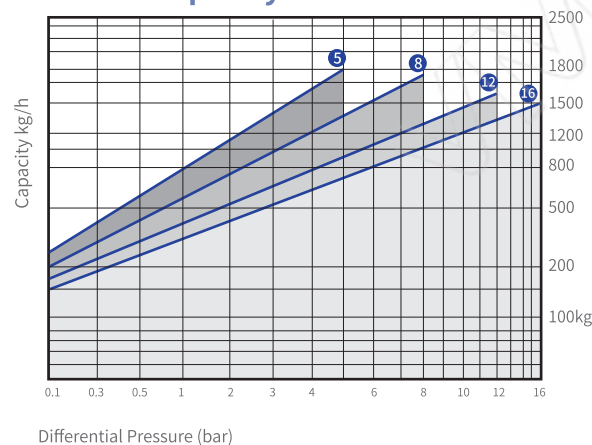

Differential Pressure (bar)

Technical Parameters

Nominal pressure	PN25
Max. allowable pressure (Shell)	2.45MPa/200°C
Max. allowable temperature (Shell)	450°C/1.03MPa
Factory steam action test	>3 times/1.6MPa
Max. working pressure	1.6MPa
Max. operating temperature	350°C
Factory cold test pressure	3.8MPa
Air test	2.0MPa

Material List

Bonnet: A105/F304/F316 Disc: Martensitic Stainless Steel
 Body: WCB/CF8/CF8M Other Internal Parts:
 Seat: Martensitic Stainless Steel Austenitic Stainless Steel

SFT30A Capacity Chart

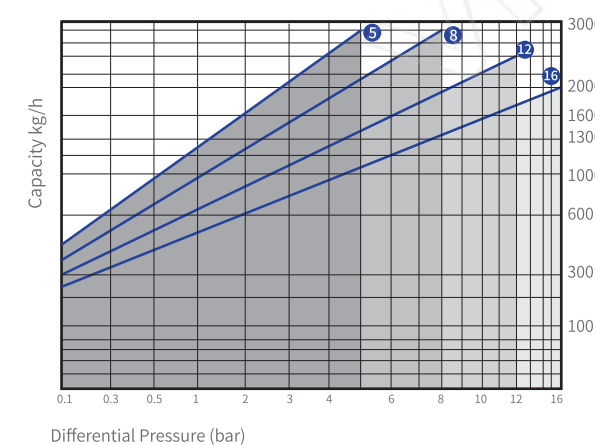

Differential Pressure (bar)

Working Principle

- Based on the density of vapor and liquid.

Features

- The body and bonnet are made of cast steel/forged steel.
- All internal parts are made of stainless steel, and the wear allowance has been fully considered in the design of movable parts, which improves the service life of the trap.
- Special flow channel design achieves zero water hammer.
- Patented flexible closing system and micron-level precision closing system double guarantee no steam leakage and long service life.
- Built-in air exhaust valve to prevent steam lock.
- The independent filter makes the trap work in a clean environment.
- Choose different capacity chart according to the pressure.
- The back pressure rate is as high as 95%
- The drain plug is designed at the bottom of the trap to ensure that the internal water will be removed, to prevent floating ball from freezing in cold weather.

Technical Standard

- GB/T12250-2005 Steam Traps Terminology Marking
- GB/T22654-2008 Technical Conditions for Steam Traps
- GB/T12251-2005 Test Method for Steam Traps
- ISO 6948 Automatic steam traps

Production and performance characteristic tests

Structure Diagram

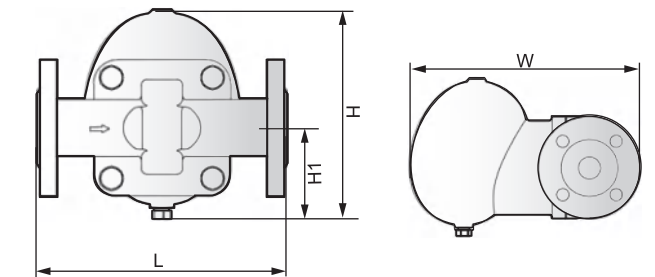

Dimension Table

Model	Size	L	H	H1	W	Weight
SFT30AT	DN25-32	170	208	87	258	12 kg
SFT30AW	DN25-32	170	208	87	258	12 kg
SFT30AF	DN25-50	230	208	87	300	16.5 kg

Lever Ball Float Steam Trap

Lever Ball Float Steam Trap

SFT40A Lever Ball Float Steam Trap

Lever Ball Float Steam Trap SFT50

Working Principle

- Based on the density of vapor and liquid.

Features

- The body and bonnet are made of cast steel/forged steel.
- All internal parts are made of stainless steel, and the wear allowance has been fully considered in the design of movable parts, which improves the service life of the trap.
- Special flow channel design to achieves zero water hammer.
- Patented flexible closing system and micron-level precision closing system double guarantee no steam leakage and long service life.
- Built-in air exhaust valve to prevent air lock.
- The independent filter makes the trap work in a clean environment.
- Choose different capacity chart according to the pressure.
- The back pressure rate is as high as 95%
- The drain plug is designed at the bottom of the trap to ensure that the internal water will be removed, to prevent floating ball from freezing in cold weather.

Technical Standard

- GB/T12250-2005 Steam Traps Terminology Marking Structure Length
- GB/T22654-2008 Technical Conditions for Steam Traps
- GB/T12251-2005 Test Method for Steam Traps
- ISO 6948 Automatic steam traps Production and performance characteristic tests

Structure Diagram

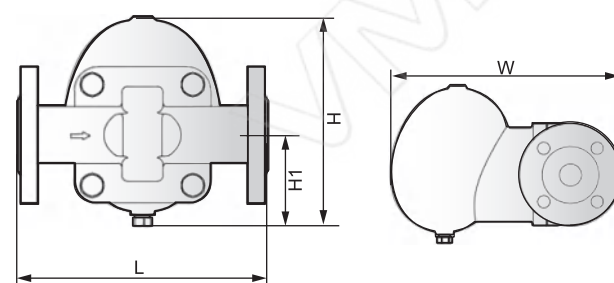

Dimension Table

Model	Size	L	H	H1	W	Weight
SFT40AT	DN25-32	210	254	107	315	20 kg
SFT40AW	DN25-32	210	254	107	315	20 kg
SFT40AF	DN25-50	270	254	107	315	26 kg



Technical Parameters

Nominal pressure	PN40
Max. allowable pressure (Shell)	3.92MPa/200°C
Max. allowable temperature (Shell)	450°C/1.66MPa
Factory steam action test	>3 times/1.6MPa
Max. working pressure	3.2MPa
Max. operating temperature	350°C
Factory cold test pressure	6.0MPa
Air test	2.0MPa

Material List

- Bonnet: WCB
- Body: WCB
- Seat: Martensitic Stainless Steel
- Disc: Martensitic Stainless Steel
- Other Internal Parts: Austenitic Stainless Steel

SFT50 Capacity Chart

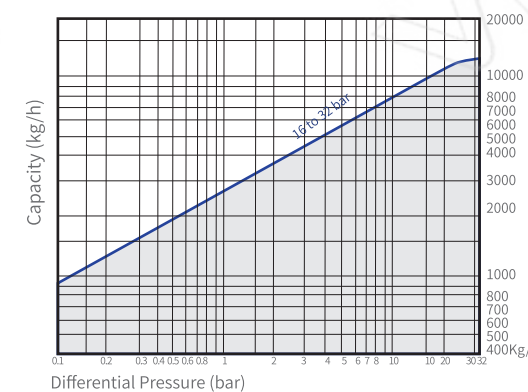

Working Principle

- Based on the density of vapor and liquid.

Features

- The valve body and bonnet are made of cast steel/forged steel.
- All internal parts are made of stainless steel, and the wear allowance has been fully considered in the design of movable parts, which improves the service life of the trap.
- Special flow channel design achieves zero water hammer.
- Double balanced seat for long service life.
- Built-in air exhaust valve to prevent steam lock.
- Water seal design, no original steam leakage.
- Choose different capacity chart according to the pressure.
- The back pressure rate is as high as 95%
- The drain plug is designed at the bottom of the trap to ensure that the internal water will be removed, to prevent floating ball from freezing in cold weather.

Technical Standard

- GB/T12250-2005 Steam Traps Terminology Marking Structure Length
- GB/T22654-2008 Technical Conditions for Steam Traps
- GB/T12251-2005 Test Method for Steam Traps
- ISO 6948 Automatic steam traps Production and performance characteristic tests

Structure Diagram

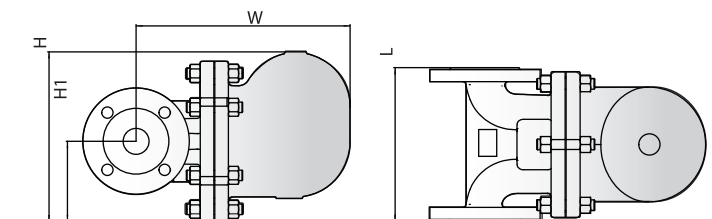

Dimension Table

Model	Size	L	H	H1	W	Weight
SFT50	DN32	230	260	120	331	27.5 kg
	DN40	230	260	120	331	27 kg

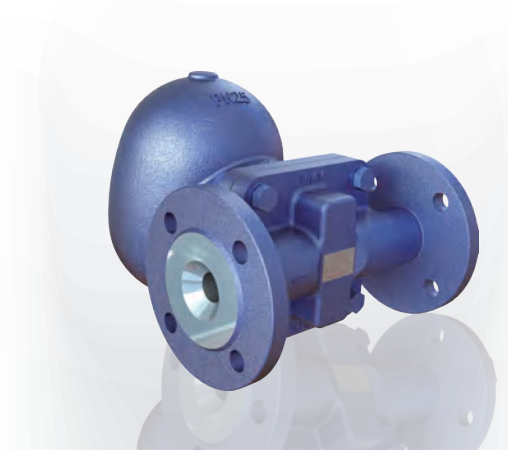

Technical Parameters

Nominal pressure	PN25
Max. allowable pressure (Shell)	2.45MPa/200°C
Max. allowable temperature (Shell)	450°C/1.03MPa
Factory steam action test	>3 times/1.6MPa
Max. working pressure	1.6MPa
Max. operating temperature	350°C
Factory cold test pressure	3.8MPa
Air test	2.0MPa

Material List

- Bonnet: A105/F304/F316
- Body: WCB/CF8/CF8M
- Seat: Martensitic Stainless Steel
- Disc: Martensitic Stainless Steel
- Other Internal Parts: Austenitic Stainless Steel

SFT40A Capacity Chart

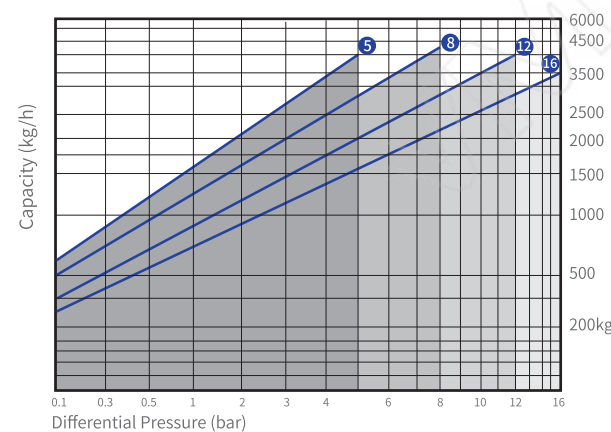

Lever Ball Float Steam Trap

Lever Ball Float Steam Trap

SFT60 Lever Ball Float Steam Trap

Lever Ball Float Steam Trap SFT66

Working Principle

- Based on the density of vapor and liquid.

Features

- The body and bonnet are made of cast steel/forged steel.
- All internal parts are made of stainless steel, and the wear allowance has been fully considered in the design of movable parts, which improves the service life of the trap.
- Special flow channel design achieves zero water hammer.
- Double balanced seat for long service life.
- Built-in air exhaust valve to prevent steam lock.
- Water seal design, no original steam leakage.
- Choose different capacity chart according to the pressure.
- The back pressure rate is as high as 95%
- The drain plug is designed at the bottom of the trap to ensure that the internal water will be removed, to prevent floating ball from freezing in cold weather.

Technical Standard

- GB/T12250-2005 Steam Traps Terminology Marking Structure Length
- GB/T22654-2008 Technical Conditions for Steam Traps
- GB/T12251-2005 Test Method for Steam Traps
- ISO 6948 Automatic steam traps Production and performance characteristic tests

Structure Diagram

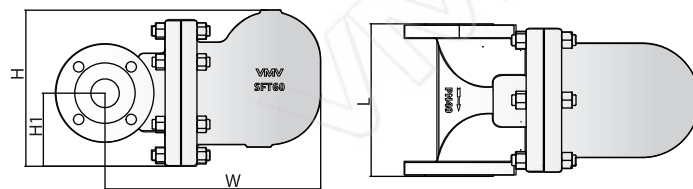

Dimension Table

Unit(mm)						
Model	Size	L	H	H1	W	Weight
SFT60	DN32	230	262	125	363	31 kg
	DN40	230	262	125	363	32kg
	DN50	230	262	125	363	33 kg



Technical Parameters

Nominal pressure	PN40
Max. allowable pressure (Shell)	3.92MPa/200°C
Max. allowable temperature (Shell)	450°C/1.66MPa
Factory steam action test	>3 times/1.6MPa
Max. working pressure	3.2MPa
Max. operating temperature	350°C
Factory cold test pressure	6.0MPa
Air test	2.0MPa

Material List

- Bonnet: WCB
- Body: WCB
- Seat: Martensitic Stainless Steel
- Disc: Martensitic Stainless Steel
- Other Internal Parts: Martensitic Stainless Steel

SFT60 Capacity Chart

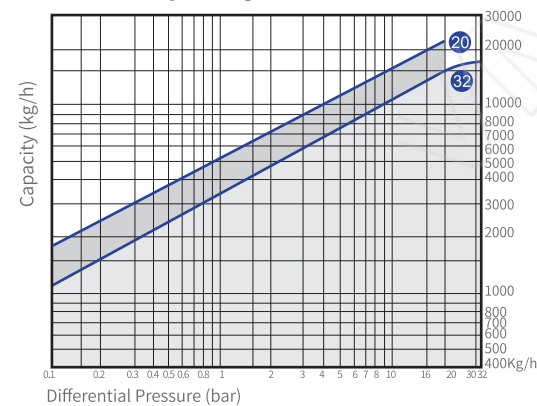

Technical Parameters

Nominal pressure	PN100
Max. allowable pressure (Shell)	9.8Mpa/200°C
Max. allowable temperature (Shell)	450°C/7.29MPa
Factory steam action test	>3 times/1.6MPa
Max. working pressure	8.0MPa
Max. operating temperature	425°C
Factory cold test pressure	15.0MPa
Air test	2.0MPa

Material List

- Bonnet: WC6
- Body: WC6
- Seat: Martensitic Stainless Steel
- Disc: Martensitic Stainless Steel
- Other Internal Parts: Martensitic Stainless Steel

SFT66 Capacity Chart

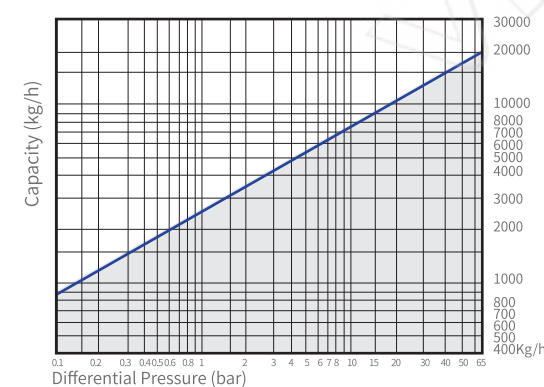

Working Principle

- Based on the density of vapor and liquid.

Features

- The body and bonnet are made of cast steel/forged steel.
- All internal parts are made of stainless steel, and the wear allowance has been fully considered in the design of movable parts, which improves the service life of the trap.
- Special flow channel design achieves zero water hammer.
- Double balanced seat for long service life.
- Built-in air exhaust valve to prevent steam lock.
- Water seal design, no original steam leakage.
- Choose different capacity chart according to the pressure.
- The back pressure rate is as high as 95% .

Technical Standard

- GB/T12250-2005 Steam Traps Terminology Marking Structure Length
- GB/T22654-2008 Technical Conditions for Steam Traps
- GB/T12251-2005 Test Method for Steam Traps
- ISO 6948 Automatic steam traps Production and performance characteristic tests

Structure Diagram

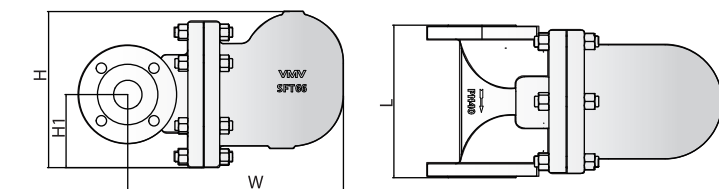

Dimension Table

Unit(mm)						
Model	Size	L	H	H1	W	Weight
SFT66	DN50	230	267	114	378	41 kg
	DN65	230	267	114	378	42kg
	DN80	230	267	114	378	44 kg

Lever Float Steam Trap

Lever Float Steam Trap

SFT70 Lever Float Steam Trap

Lever Float Steam Trap SFT80

Working Principle

- Based on the density of vapor and liquid.

Features

- The body and bonnet are made of cast steel/forged steel.
- All internal parts are made of stainless steel, and the wear allowance has been fully considered in the design of movable parts, which improves the service life of the trap.
- Special flow channel design achieves zero water hammer.
- Double balanced seat for long service life.
- Built-in air exhaust valve to prevent steam lock.
- Water seal design, no original steam leakage.
- Choose different displacement curves according to the pressure.
- The back pressure rate is as high as 95% .

Technical Standard

- GB/T12250-2005 Steam Traps Terminology Marking Structure Length
- GB/T22654-2008 Technical Conditions for Steam Traps
- GB/T12251-2005 Test Method for Steam Traps
- ISO 6948 Automatic steam traps Production and performance characteristic tests

Structure Diagram

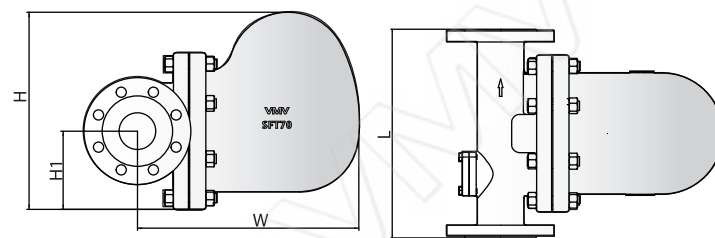

Dimension Table

Model	Size	Unit(mm)				Weight
		L	H	H1	W	
SFT70	DN50	360	343	135	385	53 kg
	DN65	360	343	135	385	54kg
	DN80	360	343	135	385	56 kg



Features

- The body and bonnet are made of heat-resistant steel casting material.
- All internal parts are made of stainless steel, and the wear allowance has been fully considered in the design of movable parts, which improves the service life of the trap.
- Double balanced seat for long service life.
- Up and down the flow path to ensure that there is no locking.
- Water seal design, no original steam leakage.
- The back pressure rate is as high as 95% .

Technical Parameters

Nominal pressure	PN40
Max. allowable pressure (Shell)	3.92MPa/200°C
Max. allowable temperature (Shell)	450°C/1.66MPa
Factory steam action test	>3 times/1.6MPa
Max. working pressure	3.2MPa
Max. operating temperature	350°C
Factory cold test pressure	6.0MPa
Air test	2.0MPa

Material List

- Bonnet: WCB
- Body: WCB
- Seat: Martensitic Stainless Steel
- Disc: Martensitic Stainless Steel
- Other Internal Parts: Martensitic Stainless Steel

Technical Standard

- GB/T12250-2005 Steam Traps Terminology Marking Structure Length
- GB/T22654-2008 Technical Conditions for Steam Traps
- GB/T12251-2005 Test Method for Steam Traps
- ISO 6948 Automatic steam traps Production and performance characteristic tests



Technical Parameters

Nominal pressure	PN40
Max. allowable pressure (Shell)	3.92MPa/200°C
Max. allowable temperature (Shell)	450°C/1.66MPa
Factory steam action test	>3 times/1.6MPa
Max. working pressure	3.2MPa
Max. operating temperature	350°C
Factory cold test pressure	6.0MPa
Air test	2.0MPa

Material List

- Bonnet: WCB
- Body: WCB
- Seat: Martensitic Stainless Steel
- Disc: Martensitic Stainless Steel
- Other Internal Parts: Martensitic Stainless Steel

SFT70 Capacity Chart

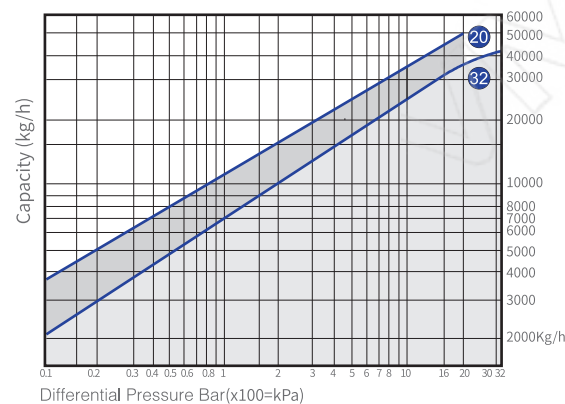

SFT80 Capacity Chart

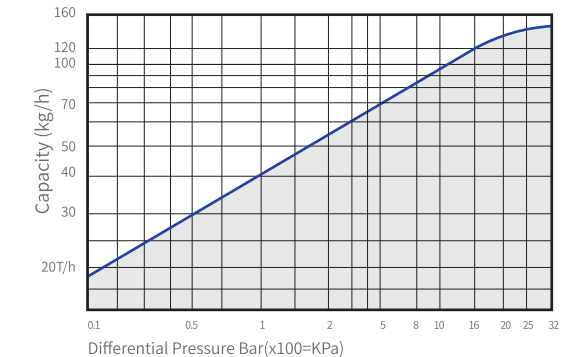

Lever Ball Float Steam Trap

Steam Liquid Two Phase Flow Trap

SFT80 Lever Ball Float Steam Trap

Automatic Level Control Device for Vapour-Liquid Two-Phase Flow Trap **QYL**
Working Principle



SFT80

SFT80A

SFT80B

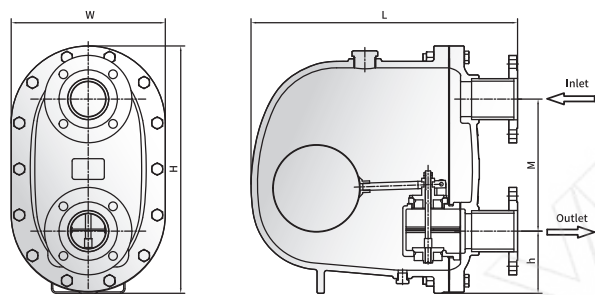

SFT80 Dimension Table

Unit(mm)							
Model	Size	L	H	W	h	M	Weight
SFT80	DN80	570	538	335	135	287	138kg
	DN100	590	838	335	135	287	145kg
	DN150	630	565	335	135	287	150kg

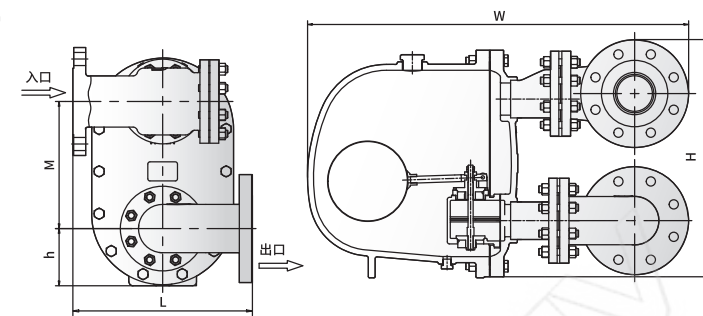

SFT80A Dimension Table

Unit(mm)							
Model	Size	L	H	W	h	M	Weight
SFT80A	DN80	310	480	620	135	287	160kg
	DN100	350	540	900	135	287	185kg
	DN150	420	610	960	135	287	200kg

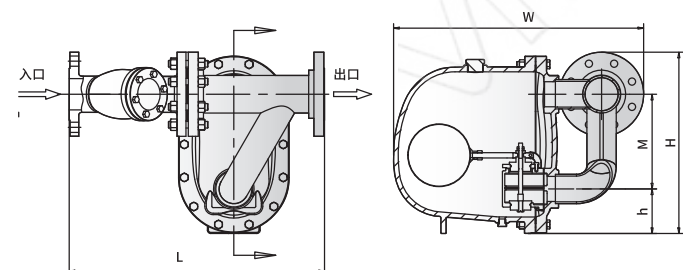

SFT80B Dimension Table

Unit(mm)							
Model	Size	L	H	W	h	M	Weight
SFT80B	DN80	720	530	740	135	287	160kg
	DN100	775	550	758	135	287	190kg
	DN150	900	570	775	135	287	210kg

Technical Parameters

Nominal pressure	PN40
Max. allowable pressure (Shell)	3.92MPa/200°C
Max. allowable temperature (Shell)	450°C/1.66MPa
Factory steam action test	>3 times/1.6MPa
Max. working pressure	3.2MPa
Max. operating temperature	350°C
Factory cold test pressure	6.0MPa
Air test	2.0MPa

Material List

Bonnet: WCB
 Body: WCB
 Seat: Martensitic Stainless Steel
 Disc: Martensitic Stainless Steel
 Other Internal Parts: Austenitic Stainless Steel

Structure Diagram Dimension Table

Unit(mm)			
Model	Size	L	H
QYL-16	65-50	235	205
	80-50	255	210
	100-50	265	225
	125-50	265	265
	150-80	265	265
QYL-40	80-50	327	240
	100-50	269	287
	125-80	260	245
	150-80	364	305

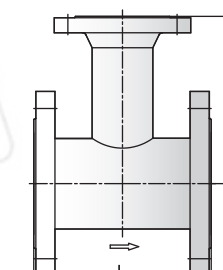

After the drainage flows through the specially designed front-end valve core and is blocked, it enters the valve chamber. The liquid level in the container slowly rises to the interface of the phase change tube, and the phase change tube changes from a vapor phase signal to a liquid phase signal. At this time, the front end drainage and liquid phase pipe drainage mix and flow towards the designated rear end throat. Due to the unchanged throat area setting, the maximum drainage displacement occurs when the liquid level rises to the required normal water level (the rear valve core is the control expansion end); When the liquid level decreases, the steam consumption signal increases and enters the regulator, reducing the effective flow area of the throat drainage and the drainage discharge, thereby achieving the purpose of controlling the water level.

Features

- Phase change tube (signal tube): To collect vapor and liquid phase signals based on the liquid level.
- Self regulating liquid level controller: The main equipment for controlling the liquid level.
- Bypass valve: A gate valve that corrects errors caused by inaccurate parameter provision.
- Inlet valve: A gate valve.
- Steam valve: A gate valve.
- Heater
- Connection short pipe

Illustration

1. Max. design working pressure $\leq 16\text{MPa}$
 2. Max. design working temperature $\leq 455\text{ }^\circ\text{C}$
- When the original drainage pipe diameter $\text{DN} > 150$, connect with a reducing pipe, When $\text{DN} \leq 150$, products of the same specification can be directly selected.
4. Adjust the steam consumption is approximately 3% of the drainage volume flow rate.

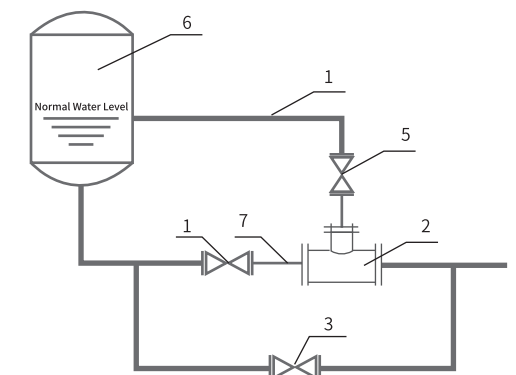

Air Trap

Air Trap

The basic concept of air trap is an automatic device that discharges the water (or liquid) in the air storage tank, gas equipment and non condensable gas pipeline through the drain valve without gas leakage. The drainage of air pipeline is called air trap, and using in non condensable gas pipeline is called drain valve. Air traps are characterized by large capacity,

long life, good energy-saving effects, water hammer resistance, and beautiful appearance. They are widely used in compressed air or non condensable gas tanks, pipelines and air separation equipment. The technical advantages of VMV traps are unique and reasonable structure and high-precision internals!

High Strength Corrosion Resistance

Using WCB material, full consideration of corrosion allowance, minimum shell wall thickness, pressure and temperature rating.

Flexible Closing System

Single valve seat and flexible closing system are adopted to ensure super long service life and closing accuracy.

Built-in Filter Device

It can effectively prevent pipeline impurities from entering the valve, ensuring the normal operation of the trap, and prevent water hammer from damaging internal components.

Pressure Equalizing Flange

Structure with pressure equalizing balance pipe
Air blockage

Stainless Steel Float

The flawless laser-welded floating ball ensures the long working life of the steam trap

Unique Float Assembly

Precisely calculated floating ball component structure makes the closing system work under water seal without steam leakage.

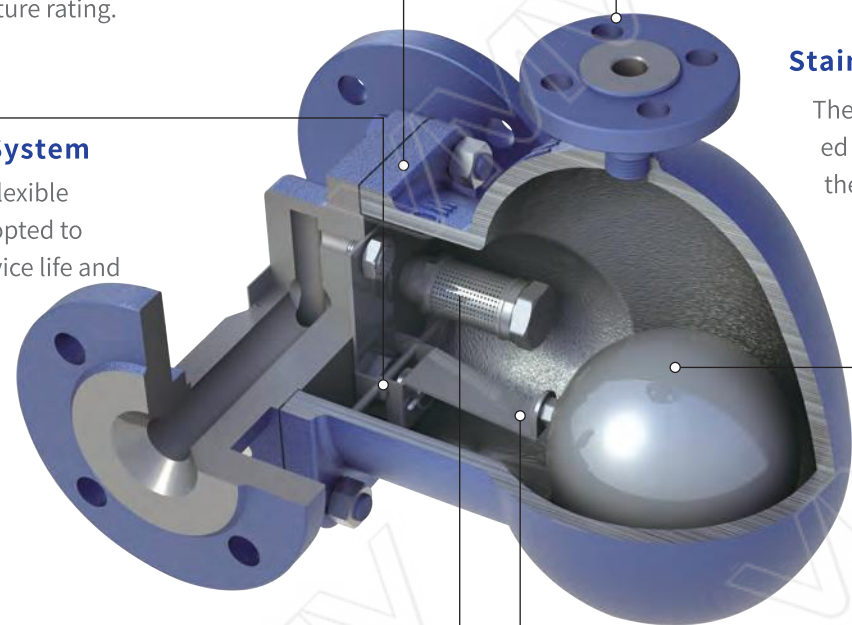

Structural Features

VMV applies the flexible closing system to air trap, which solves the problems of short life-time and bad sealing. In the design, factors such as shell strength, pressure and temperature grade, casting processability, fluid flow path, impact caused by water and vapor mixing, closing of the auxiliary water seal, and the strength of the valve cover gasket affected by the low temperature environment are fully considered. Air trap relies on the density difference between steam and condensate to work. When the valve body is full of non-condensable gas, the gas is discharged through the balance pipe, and the water enters the trap. The floating ball moves up and drives the valve core to open. After discharging the condensed water, the floating ball drives the valve core to move down and closes the drain valve. Air trap has the following advantages, long life, reliable operation, convenient maintenance, no original steam leakage. The greatest advantage of the air trap is can work under pressure as low as 0.1bar.

WCB/A105 Material PN25 Valve Body Pressure - Rating Temperature

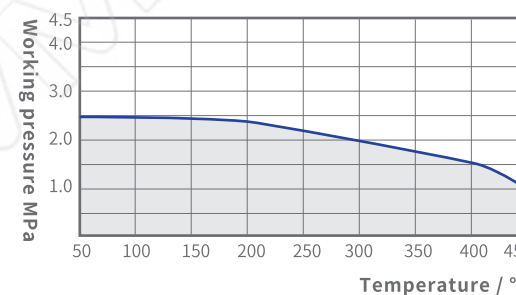

Air Trap Selection and Installation

The air trap can drain water continuously. It is suitable for discharging water or liquid from gas transmission pipeline, gas storage tank and air separation unit. Generally, the safety factor is 2-3 times when selecting models. The displacement of air trap increases with the increase of pressure difference. Check the displacement curve in detail. Special reminder: Please do not mistakenly think that the large diameter trap with large displacement. The air trap is installed horizontally at the bottom of the pipeline or equipment, being equipped with pressure equalizing and balancing pipe and flange as leaving factory-(PN25, DN10 RF). The basic configuration is shown on the graph.



The air trap is made of ASTM216 WCB cast steel, part of the valve cover is made of ASTM A105, the internals are made of stainless steel, with built-in filter.

- Nominal pressure: PN25;
- Maximum allowable temperature: 200°C/2.45MPa;
- Maximum working pressure: 2.5MPa;
- Maximum working temperature: 200°C;
- Connection type: thread RC or flange (GB/T 9115.1-2000; HG/T20615-2009; HG/T20592-2009, etc.)

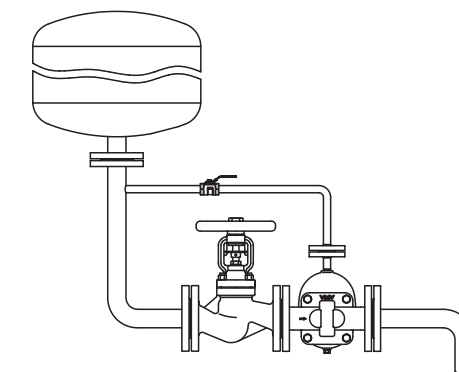

Installation method: remove the upper plug, screw on the balance pipe with flange, and connect the air inlet pipe and balance pipe.

Pump Trap System



Properties of Steam & Condensate Recovery

Pump Trap T20

Why recycle condensate

The steam generates condensate through heat exchange. The condensate is separated and discharged through the steam trap. The condensate contains a lot of heat energy.

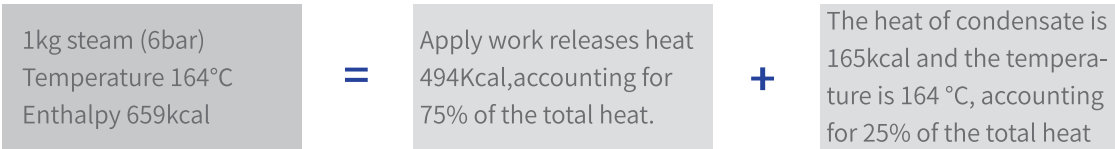

Condensate heat energy recovery method

Recovery of heat energy by flash tank

2 bar low-pressure steam 0.058 kg is generated, and the temperature is 133 °C, accounting for 19% of the total heat of condensate

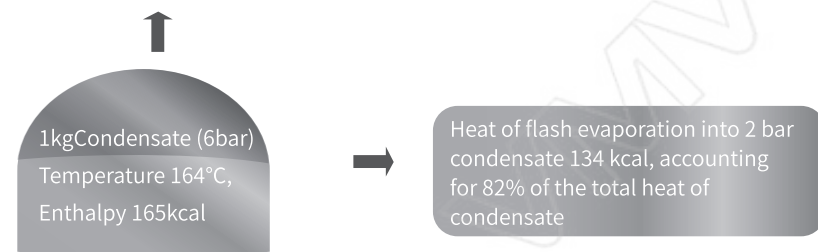

Steam trap back pressure recovers condensate heat energy

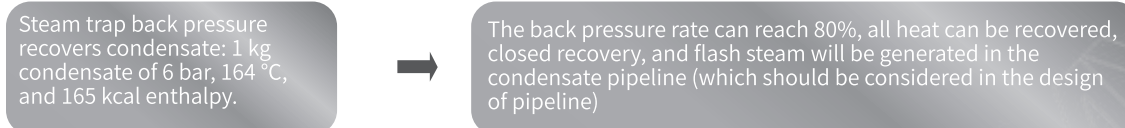

Electric pump recovers condensate heat energy

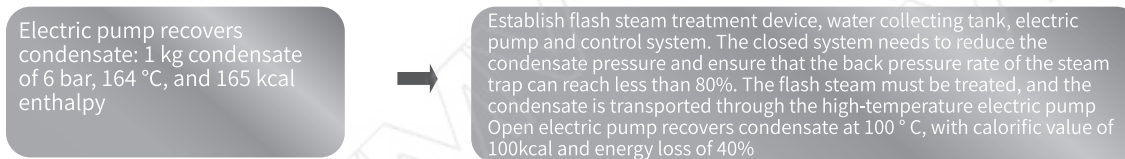

Recovers condensate heat energy

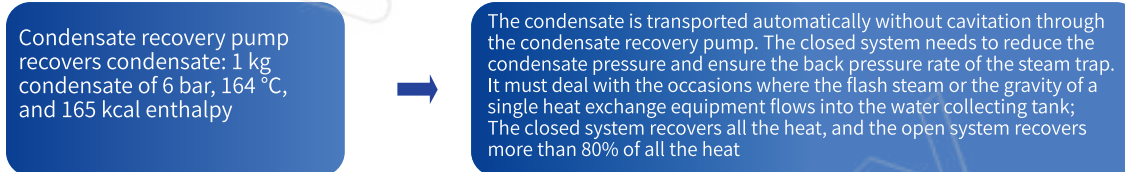

VMV condensate recovery pump (pump trap) first came from foreign technology, originally meaning "pump trap", also known as mechanical power pump. It uses the principle of steam trap and relies on steam, air and other gases as power to transport condensate from low-pressure area to high-pressure area, or from negative pressure area (vacuum) to normal pressure area.

Condensate recovery pump has a series of advantages, such as automatic control, no cavitation, simple maintenance, no need for electricity, water hammer resistance, large capacity, explosion-proof, no noise, and the head of delivery determined by the pressure of power steam (gas), which is unmatched by other pumps. It is widely used in the transportation of condensate in steam system and liquid with low viscosity and no volatilization.

Convenient Replacement and Maintenance

Open the valve cover at a glance without removing the pipe connection

High Corrosion Resistance

High temperature alloy spring is used for long-term stable operation at 540°C

Valve Core and Valve Seat

The valve seat and valve core are made of stainless steel, and the closing pair adopts flexible closing system with small wear, reliable closing and long service life

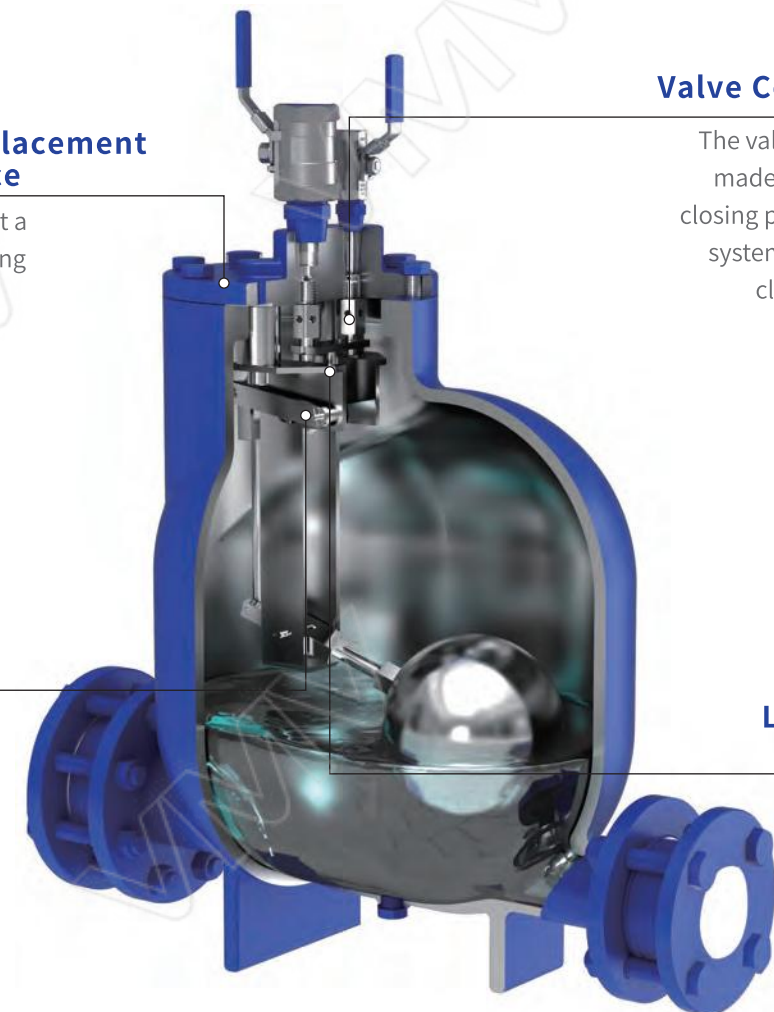

Long Life and High Precision

Welding of key parts
The accuracy of key parts of stellite alloy can reach μm level
The key parts are welded with Stellite alloy, and the precision of key parts can reach micron level

Selection Conditions of Pump Trap

1. Condensate delivery capacity kg / h
2. Back pressure (head of delivery) MPa
3. Power steam (air)
4. Power steam (air) pressure MPa
5. Water inlet normal diameter DN
6. Water outlet normal diameter DN

Pump Trap

Pump Trap

Pump Trap **PT20**

Working Principle

Enter condensate and exhaust steam(air)

At the beginning, the water inlet check valve is opening, the water outlet check valve is closed due to high back pressure, the water start to enter the pump, and the floating ball is at a low level, with the rise of water level and the opening of exhaust valve, the floating ball reaches the highest controller and is in the switching critical state.

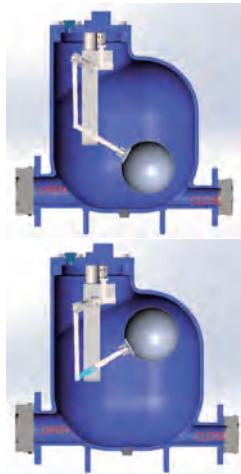

Enter steam(air) and exhaust condensate

The controller starts switching at the high position and closes the exhaust valve: open the power steam (air), inject steam into the valve, and push the condensate in the pump to the high-pressure area under the steam pressure: at this time, the water inlet check valve cannot feed water due to the high pressure in the pump. When the floating ball reaches the low position, the controller switches to close the power steam and opens the exhaust valve to enter the next action cycle.

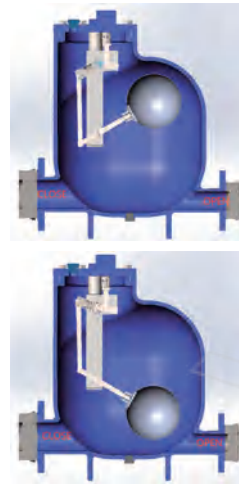

Technical Parameter

Design Standards

- GB / T22654-2008 Technical conditions for steam traps
- GB / T12251-2005 Test methods for steam traps
- GB / T12224-2005 General requirements for steel valves

Nominal pressure	PN16(150LB)	Design pressure of valve body	2.5MPa	Water inlet diameter	DN80 RF
Maximum allowable pressure	1.6MPa/204°C	Maximum allowable temperature	300°C /1.23MPa	Water outlet diameter	DN50 RF
Maximum working pressure	1.37MPa/250°C	Maximum operating temperature	250°C /1.37MPa	Steam outlet diameter	1" RC
Maximum power steam inlet pressure	1.37MPa	Steam (Air) consumption	Steam 5kg / T condensate air 7.6m3/T condensate	Steam inlet diameter	1/2" RC

Material List of Main Parts

Valve body,cap	WCB	Float	304
Valve seat	420	Control rack	304+Stellite
Valve core	440C	Fastener	Carbon steel grade 8.8
Spring	Ni Base Superalloy	Gasket	SS304+flexible graphite

WCB/A105Material PN16 valve shell pressure temperature rating

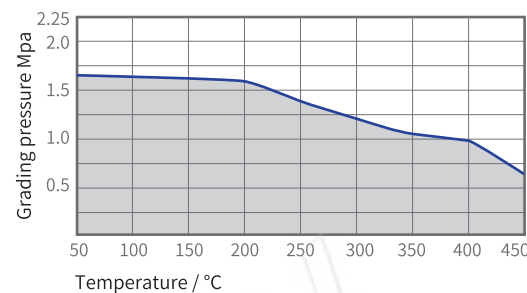

Performance Characteristics

- Non electric drive, driven by steam or compressed air, explosion-proof and safe, and can be used in any environment.
- Compact structure, without any requirements for installation, even in the open field, its normal operation will not be affected.
- Automatic control, the amount of the water output is determined by the water inflow. When the amount of condensate increases, the working frequency increases, when it decreases, the working frequency decreases, and the work stops once there's no condensate.
- No cavitation work, which completely overcomes the cavitation defect of electric pump.
- All stainless steel internals and special materials ensure performance and service life.

Remarks

- It is recommended that the head height of fluid entering is more than 0.5m (the pump cover is the benchmark), and the "correction coefficient of inlet height" can be referred to;
- Power steam inlet connection RC1 / 2 ";
- For the normal operation of the pump, the saturated condensate needs flash or condensation treatment, and the closed system must ensure the differential pressure and back pressure rate of the normal operation of the steam trap.
- The standard configuration of condensate inlet and outlet is HG/ T20592-2009 PN16 flange connection. If ASME16.5, JIS and other standards is required, please specify.

Structure diagram

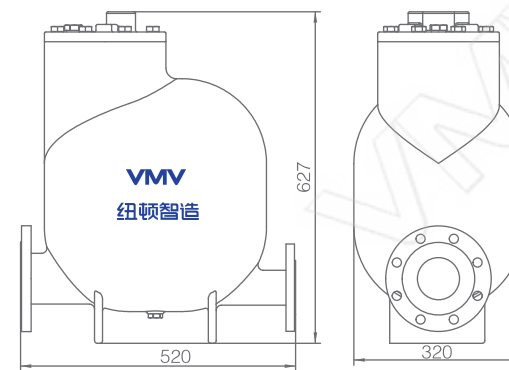

Maintenance

Attached accessories: one set of valve cap gasket and one set of valve seat gasket. Recommended spare parts list: one valve seat, one valve core and one spring.

PT20 Capacity Chart

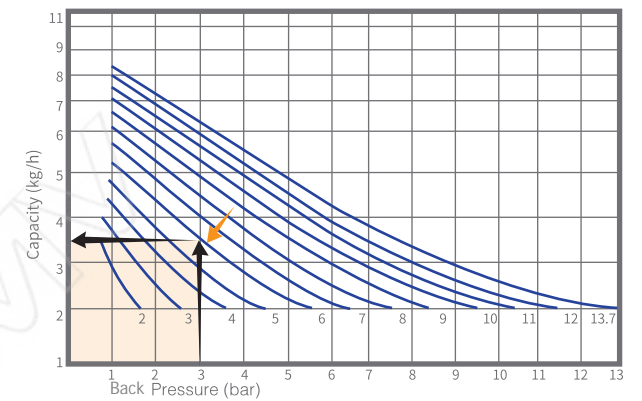

How to check the displacement

For example:
The power steam pressure is 6bar, and the back pressure at the rear end is 3bar (1bar = 10m).
Step 1: Find out the power steam 6bar curve, and see the curve pointed by the yellow arrow;
Step 2: Lift 30m, means back pressure 3bar (1bar=10m),Find the lower horizontal axis 3bar and move it up to 6bar to intersect the curve (see the black arrow);
Step 3: Move the intersection to the left to find out the capacity value and get the capacity of 3.5t/h;
Step 4: 3.5t/h x head height correction coefficient = actual capacity

Head Height Correction Coefficient

Inlet Height (m)	Capacity Correction Factor			
	DN25	DN40	DN50	DN50*DN50
0.15	0.90	0.75	0.75	0.80
0.30	1.00	1.00	1.00	1.00
0.60	1.15	1.10	1.20	1.05
0.90	1.35	1.25	1.30	1.15

Maintenance cycle:After one year of operation, open the pump cover to check the wear of mechanical parts, and open the sewage outlet for sewage discharge once without removing the connecting pipe.

Pump Trap

Pump Trap

PT10 Pump Trap

Pump Trap PT10



Product Features

1. There will be no cavitation when discharging high-temperature condensed water.
2. No need for electric drive or installation of liquid level control devices, which is safer to use.
3. Low head operation (minimum 300mm).
4. Online replacement of internal components makes cleaning very simple and reduces maintenance costs.
5. High quality stainless steel internals and hardened working surfaces ensure the reliable operation of the pump.
6. Compact structural design minimizes installation space.

Installation Precautions

Check valves must be installed at the inlet and outlet of the pump type drain valve. Choose a connection method based on the interface format. The pressure of the power medium minus the back pressure > 0.05MPa. If a closed recovery system is used, the power medium used must be consistent with the fluid being pumped. When using non condensable gases such as air and nitrogen as power media, please communicate and confirm with us.

Application

Compact pump trap is suitable for condensate discharge or recovery, with a wide range of applications. It is used to discharge low flow condensate in low level storage tanks.

Main Parts Material List

Body/Bonnet	WCB / QT450	Ball	304
Seat	420	Control frame	304
Disc	440C	Bolt	B7/2H
Spring	Inconel625	Sealing gasket	Flexible graphite

Valve Shell Pressure Temperature Rating (PN2.5MPa; WCB material)

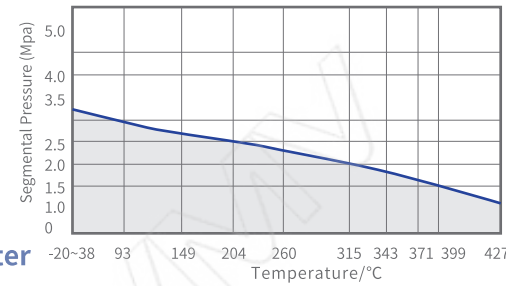

Technical Parameter

Nominal pressure	PN16(150Lb)
Max. allowable pressure	1.6MPa/204°C
Max. working pressure	1.37MPa/250°C
Max. power steam inlet pressure	1.37MPa
Valve body design pressure	2.5MPa
Max. allowable temperature	300°C /1.23MPa
Max. working temperature	250°C /1.37MPa
Steam (air) consumption	"steam 5KG/condensate air 7.6m3/condensate"
Water inlet diameter	DN40 RF
Water outlet diameter	DN25 RF
Exhaust port diameter	DN20
Air intake diameter	DN15

Steam&Air Consumption Curve

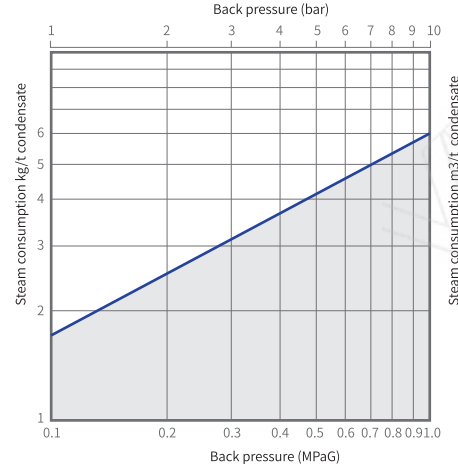

Connection : Flange
Inlet diameter: DN25
Outlet diameter: DN25
Check valve: MH71H-16P
Inlet diameter: DN25
Outlet diameter: DN25
Head height: 630mm

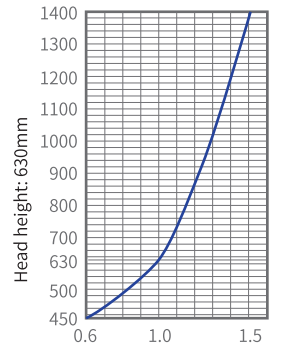
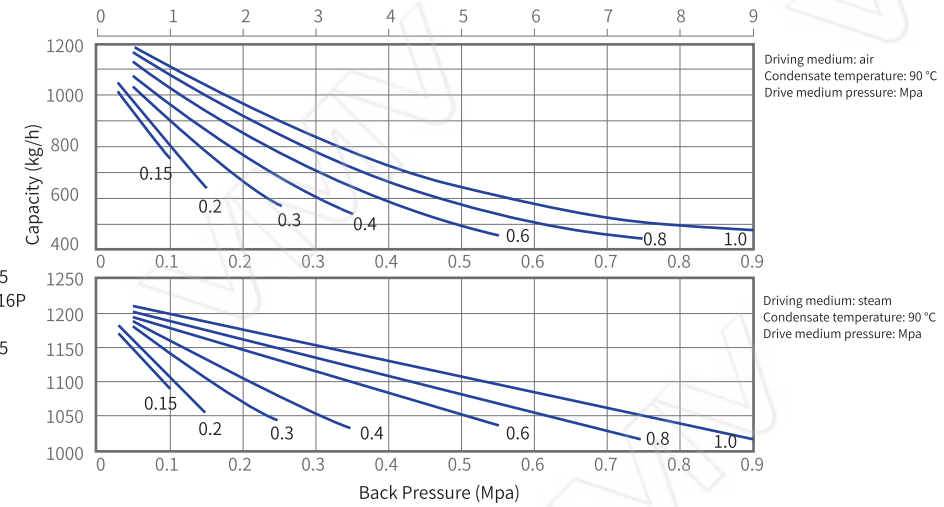

Connection : Flange
Inlet diameter: DN40
Outlet diameter: DN25
Check valve: MH71H-16P
Inlet diameter: DN25
Outlet diameter: DN25
Head height: 630mm

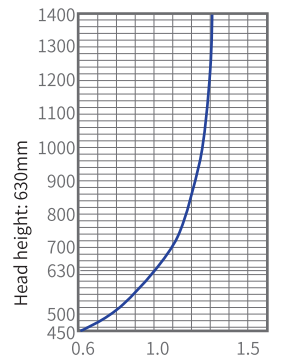
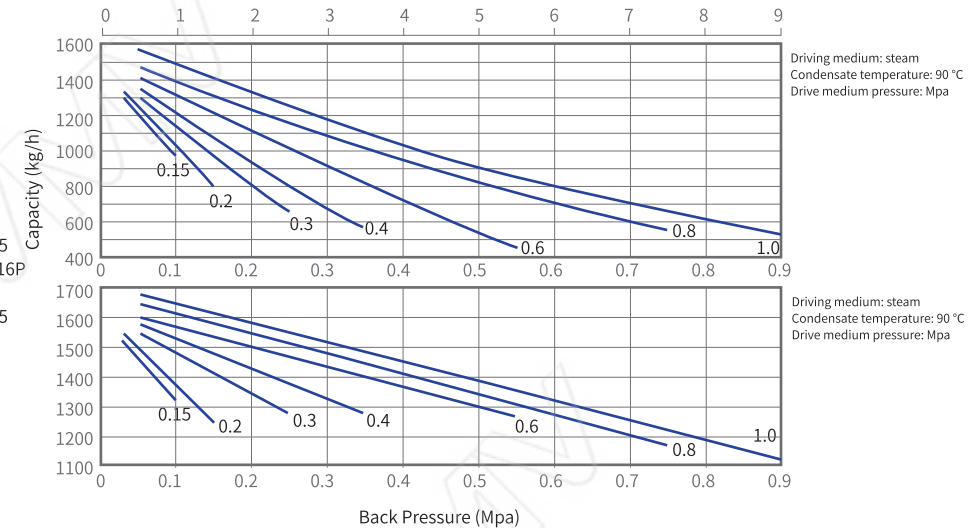

Pump Trap System

Pump Trap System

VMV pump trap system device is a complete recovery system composed of pump steam trap and control valve of water collecting tank. It only needs to be connected with power steam, inlet pipe and return pipe to operate.

According to the capacity, VMV pump trap system device is divided into single pump trap system device SPT20S, double pump trap system device SPT20D, three pump trap system device SPT20T and four pump trap system device SPT20F. According to the system, it is divided into open system and closed system.

Product Model Compilation:

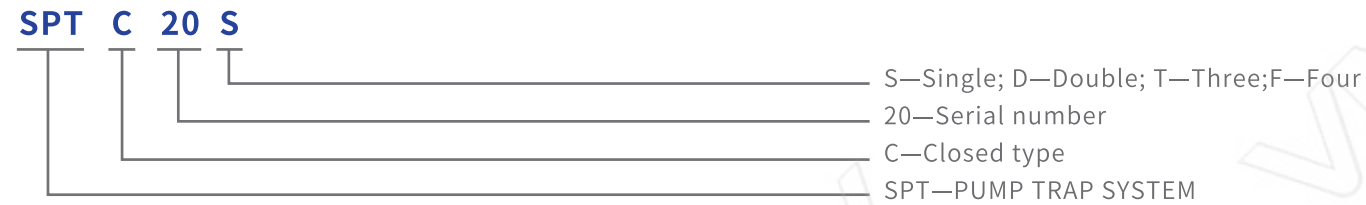

Model of open system: SPT20S, SPT20D, SPT20T, SPT20F
 Model of closed system: SPTC20S, SPTC20D, SPTC20T, SPTC20F

Pump Trap Closed System

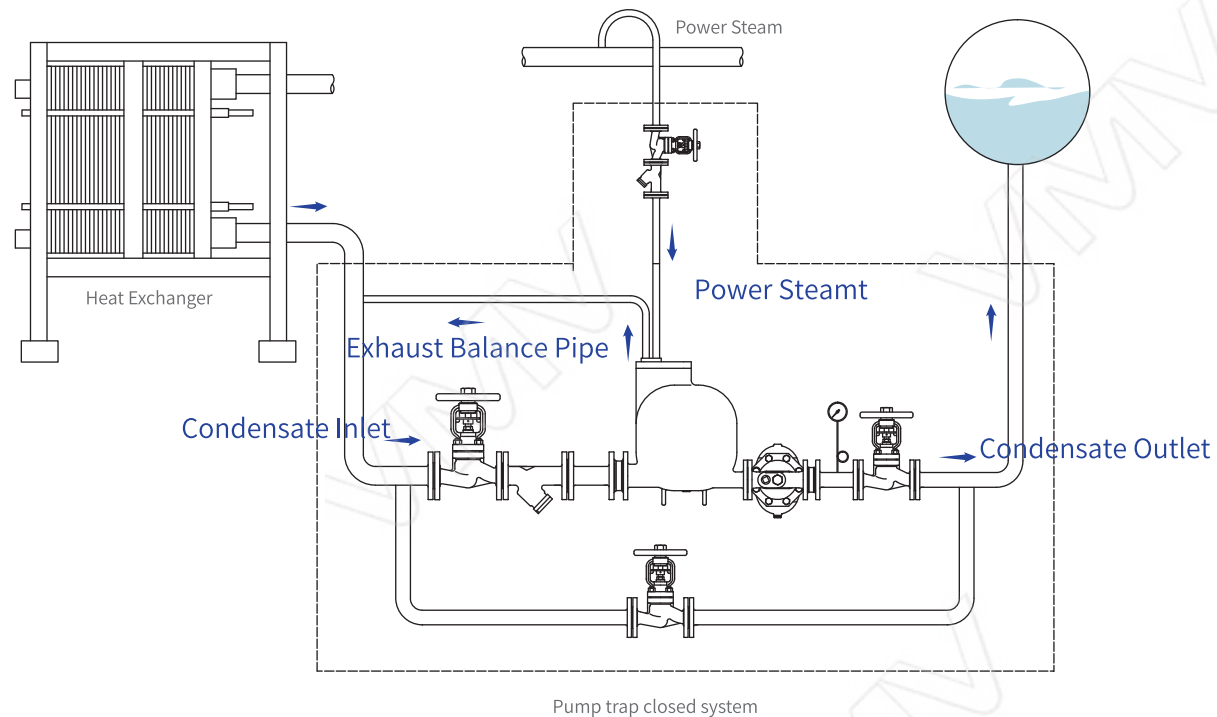

Single Pump Trap System Device (Open) SPT20S

Model: SPT20S (open system)
 Name: Single Pump Trap System Device (open)
 Weight: 280kg
 Volume: 1000x750x1688 (mm)
 Nominal pressure: PN16
 Maximum allowable pressure: 1.6mpa/204 ° c
 Maximum working pressure: 1.37mpa/250 ° c
 Flange standard: hg/t20592; pn16 rf
 Power steam consumption: 5kg / t (condensate)
 Power air consumption: 7.6m3/t (condensate)
 Limitation: The water collecting tank (upper water tank) is not under pressure and is only used as open buffer water collection.

Technical Standard

- GB/T12250-2005 Steam Traps Terminology Marking Construction Length
- GB/T22654-2008 Technical conditions of steam traps
- GB/T12251-2005 Test methods for steam traps
- ISO 6948 Automatic steam traps

Production and performance characteristic tests

Structure Chart

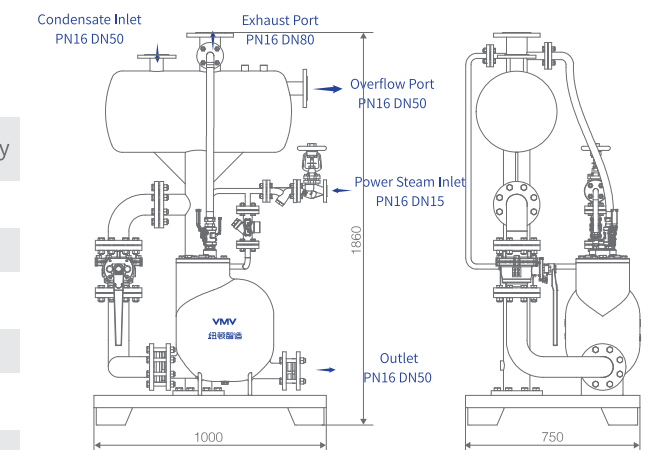

Device Configuration of Single Pump Trap System

Part Name	Part Model	Specifications	Material	Quantity
Pump Steam Trap	PT20	DN80/DN50	WCB	1
Check Valve	H71H-16P	DN80 PN16	304	1
Check Valve	H71H-16P	DN50 PN16	304	1
Open Water Collecting Tank			Q345	1
Ball Valve	Q11H-16P	DN25	304	1
Ball Valve	Q11H-16P	DN15	304	1
Steam Trap	STD16F-16	DN15	WCB	1
Bellow Seal Globe Valve	WJ41H-16C	DN15 PN16	WCB	1
Base			Q345	1
Ball Valve	Q41H-16C	DN80 PN16	WCB	1
Filter	YG4SH-16C	DN15 PN16	WCB	1
Exhaust Hose		DN25 PN16	304	1

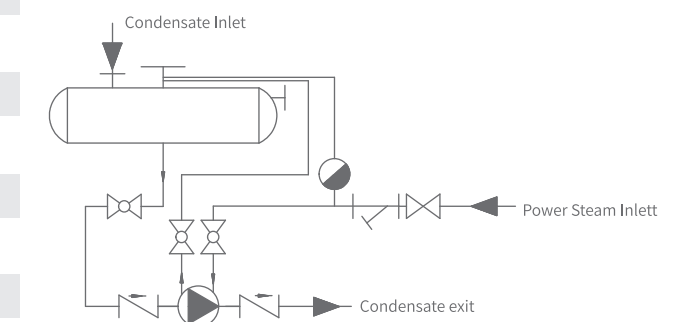

Flow Chart of Single Pump Trap System

Pump Trap System

Pump Trap System

SPT20D Double Pump Trap System Device (Open)



Model: SPT20D (open system)
 Name: Double Pump Trap System Device (Open)
 Weight: 486kg
 Volume: 1000x1200x1860 (mm)
 Nominal pressure: PN16
 Maximum allowable pressure: 1.6mpa/204 ° c
 Maximum working pressure: 1.37mpa/250 ° c
 Flange standard: hg / t20592; pn16 rf
 Power steam consumption: 5kg / t (condensate)
 Power air consumption: 7.6m3/t (condensate)
 Limitation: The water collecting tank (upper water tank) is not under pressure and is only used as open buffer water collection.

Technical Standard

- GB/T12250-2005 Steam Traps Terminology Marking
 - GB/T22654-2008 Technical conditions of steam traps
 - GB/T12251-2005 Test methods for steam traps
 - ISO 6948 Automatic steam traps
- Production and performance characteristic tests

Structure Chart

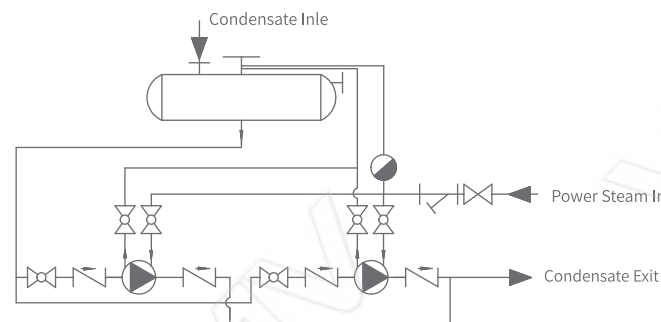
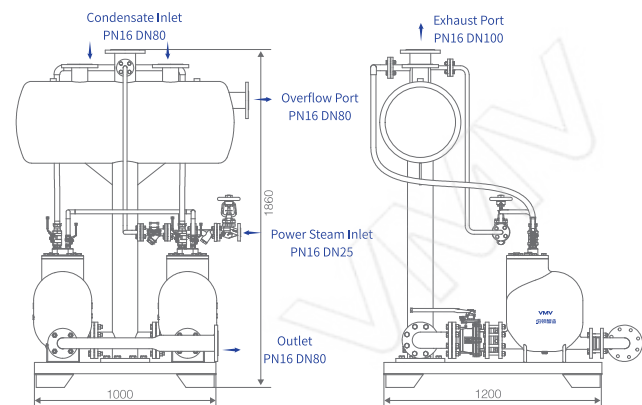

Flow chart of double pump trap system

Device Configuration of Double Pump Trap System

Part Name	Part Model	Specifications	Material	Quantity
Pump Steam Trap	PT20	DN80/DN50	WCB	2
Check Valve	H71H-16P	DN80 PN16	304	2
Check Valve	H71H-16P	DN50 PN16	304	2
Open Water Collecting Tank		Q345		1
Ball Valve	Q11H-16P	DN25	304	2
Ball Valve	Q11H-16P	DN15	304	2
Steam Trap	STD16F-16	DN15	WCB	1
Bellow Seal Globe Valve	WJ41H-16C	DN25 PN16	WCB	1
Base		Q345		1
Ball Valve	Q41H-16C	DN80 PN16	WCB	2
Filter	YG45H-16C	DN25 PN16	WCB	1
Exhaust Hose		DN25 PN16	304	2



Model: SPT20T (open system)
 Name: Three Pump Trap System Device (Open)
 Weight: 740kg
 Volume: 1670x1390x1875 (mm)
 Nominal pressure: PN16
 Maximum allowable pressure: 1.6mpa/204 ° c
 Maximum working pressure: 1.37mpa/250 ° c
 Flange standard: hg / t20592; pn16 rf
 Power steam consumption: 5kg / t (condensate)
 Power air consumption: 7.6m3/t (condensate)
 Limitation: The water collecting tank (upper water tank) is not under pressure and is only used as open buffer water collection.

Technical Standard

- GB/T12250-2005 Steam Traps Terminology Marking
 - GB/T22654-2008 Technical conditions of steam traps
 - GB/T12251-2005 Test methods for steam traps
 - ISO 6948 Automatic steam traps
- Production and performance characteristic tests

Structure Chart

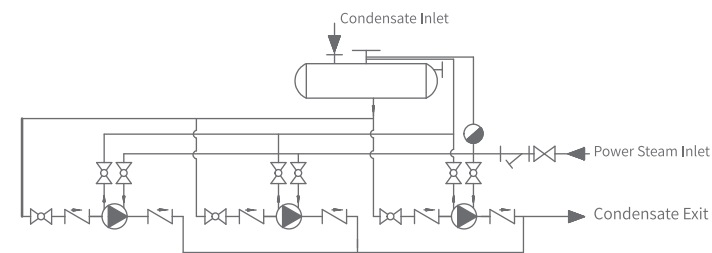
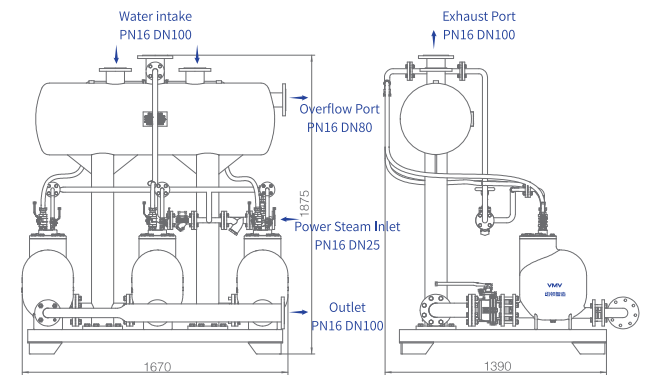

Flow chart of three pump trap system

Device Configuration of Three Pumps Trap System

Part Name	Part Model	Specifications	Material	Quantity
Pump Steam Trap	PT20	DN80/DN50	WCB	3
Check Valve	H71H-16P	DN80 PN16	304	3
Check Valve	H71H-16P	DN50 PN16	304	3
Open Water Collecting Tank		Q345		1
Ball Valve	Q11H-16P	DN25	304	3
Ball Valve	Q11H-16P	DN15	304	3
Steam Trap	STD16F-16	DN15	WCB	1
Bellow Seal Globe Valve	WJ41H-16C	DN25 PN16	WCB	1
Base		Q345		1
Ball Valve	Q41H-16C	DN80 PN16	WCB	3
Filter	Y type	DN25 PN16	WCB	1
Exhaust Hose		DN25 PN16	304	3

Heating System Solution

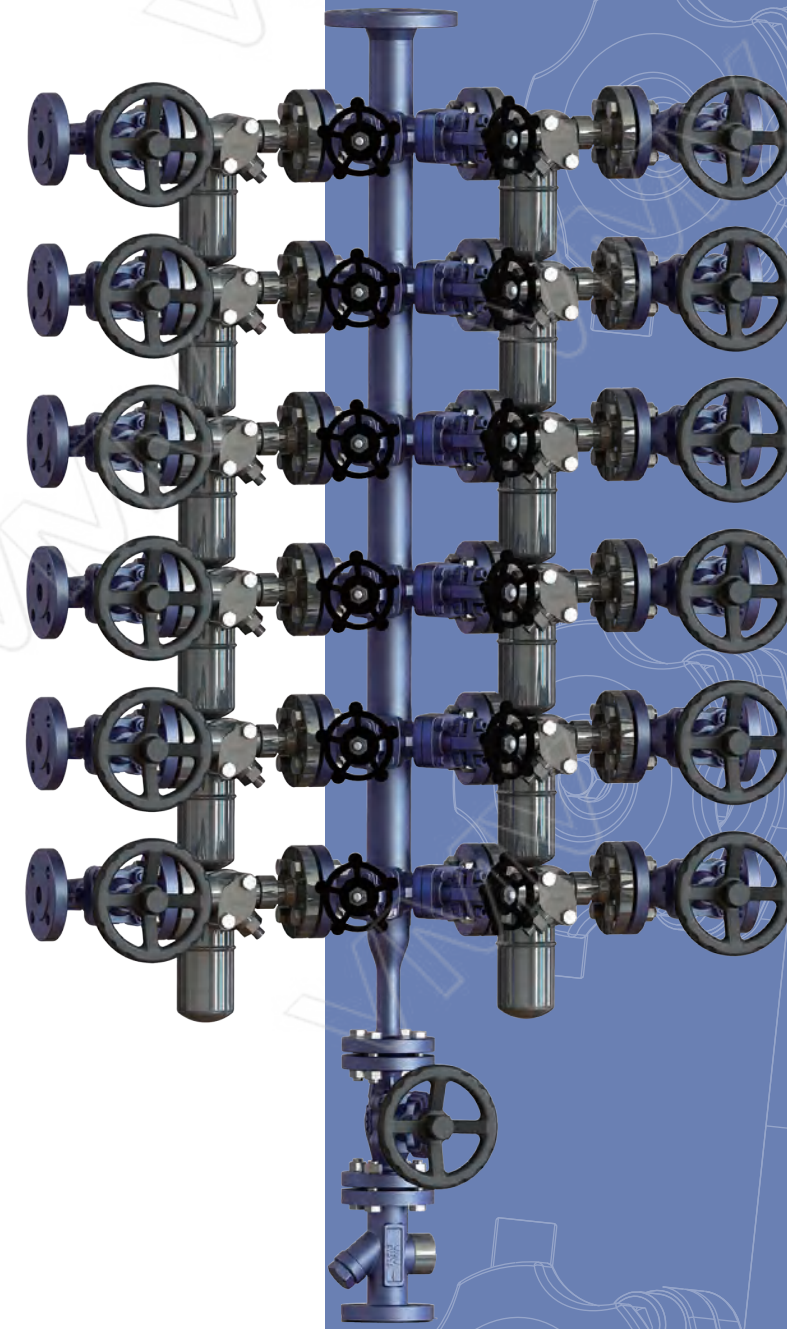

Typical Heating System

Bellows Stainless Steel Steam Manifolds

Product Description

VMV typical heat tracing system" integrates all the components required by steam distribution tube bundle and condensate collection tube bundle (steam trap, manifold, valve, etc.), and puts all the components together. The manifold is the integrated "chip" of the process pipe the device cost and providing compact and easy disassembly centralized positioning components.

Application Of Manifold

Steam distribution manifold and condensate collection manifold are widely used in petroleum refining, textile raw material chemical industry, coal chemical industry, etc. With the advantages of convenient management and maintenance, high product quality, low construction cost and short construction period.

Product Description

VMV Bellows Stainless Steel Steam Manifolds"incorporate integral bellows sealed globe valves for steam distribution and condensate collection systems. Depending on the installation,BSPM and BCRM can be used for steam distribution or condensate collection.

The main body adopts the medium temperature wax silica sol precision casting process, and the material CF8 has strong corrosion resistance.

Steam Distribution Manifold

Put all steam supply valves together. Standardized components and centralized location simplify installation, fundamentally save cost and make daily maintenance more convenient. VMV bellows seal globe valve and steam trap shall be equipped equipped.

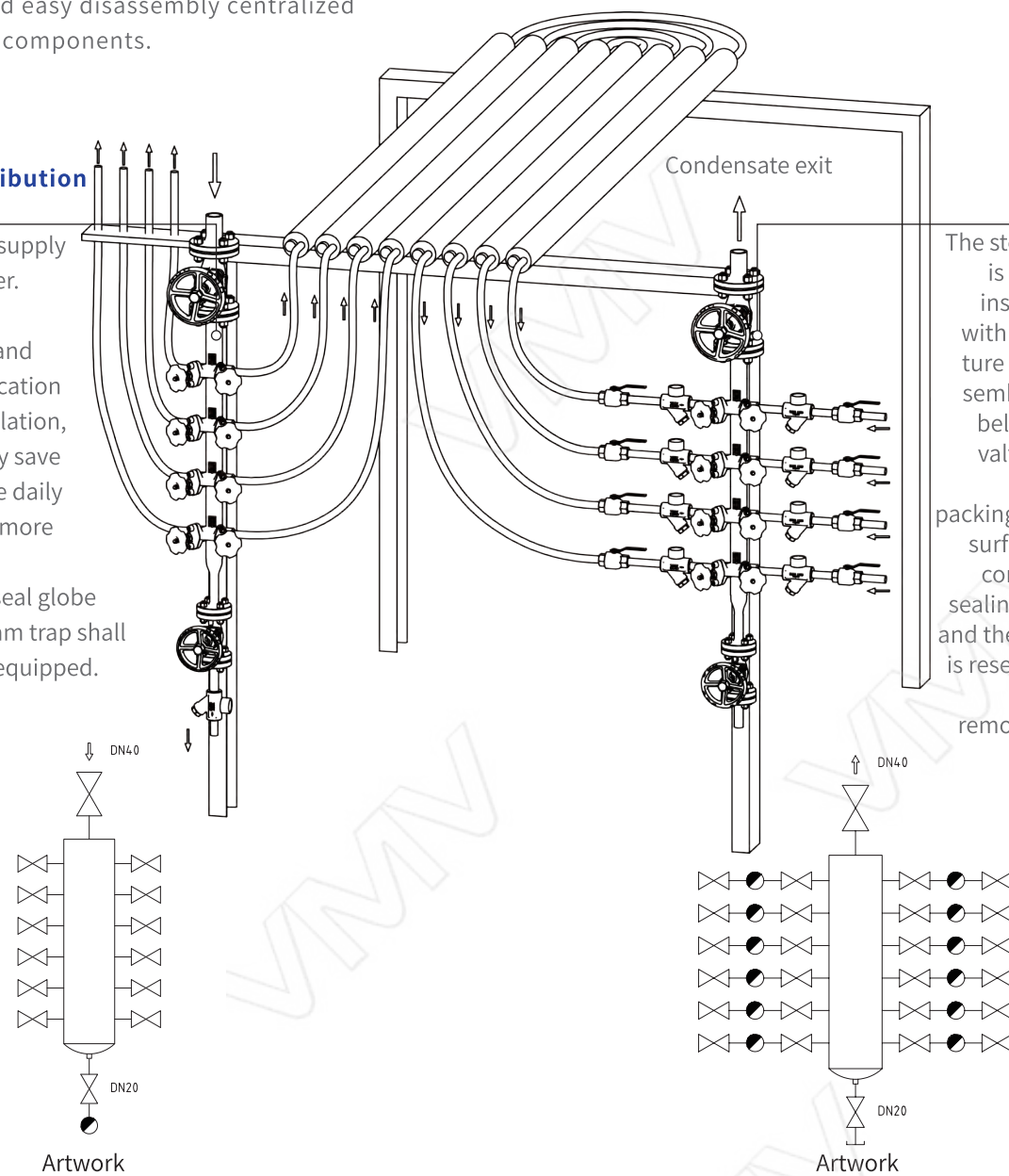

Condensate Collecting Manifold

The steam trap group is assembled and installed together, with compact structure and easy disassembly. The built-in bellows seal globe valve ensures zero leakage at the packing. The spherical surface of the valve core improves the sealing performance, and the draining valve is reserved for convenience and the removal of impurity.

Manifolds Body

High strength and corrosion resistance
Temperature resistant up to 350°C
Precision casting, exquisite appearance
Integrated, compact structure

Handwheel

Corrosion-resistant material
Beautiful
Good grip

Threaded Pressure Sleeve

Packing and thread pressure sleeve
Avoid loosening
Martensitic stainless steel
High hardness and corrosion resistance

Valve Core, Valve Seat

Integral spherical valve core
Matching Conical Seat
Achieve linear sealing
Improve sealing performance
The valve core adopts martensitic hardening treatment
Improve scour resistance

Bellows Components

Built-in stainless steel bellows components and graphite packing realize double sealing guarantee of valve stem

Concealed Drive Thread

The drive thread is placed inside the handwheel
Dustproof and waterproof,
Easy to switch

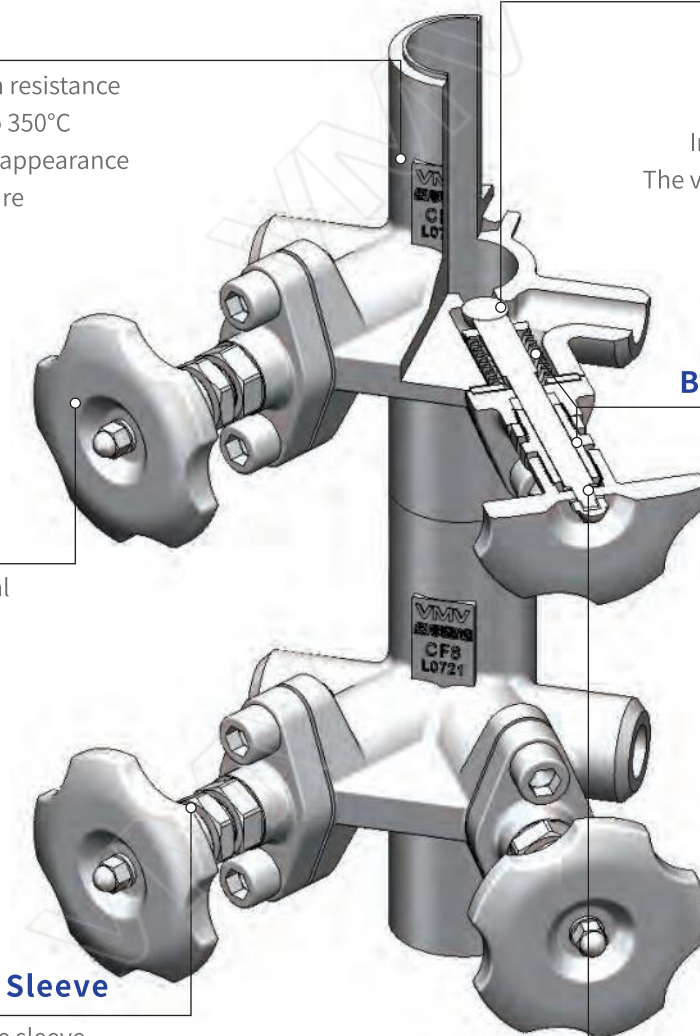

Bellows Stainless Steel Steam Distribution Manifolds

Bellows Stainless Steel Steam Distribution Manifolds

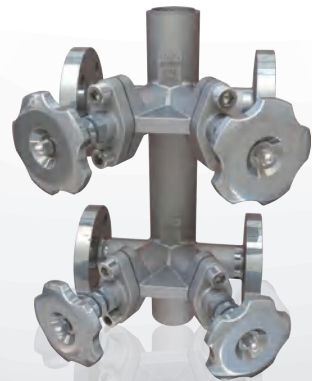

Structural Features

- Integrated design, solid structure, shorten on-site construction time.
- Maximize saving installation space and easy maintenance
- Integral ball seal face and V-line seal seat ensure perfect sealing.
- Adopting stainless steel bellows design, it is easily opened and becomes durable and non-leaking.

Technical Standard

- GB12224-1989 General Requirements For Steel Valves
- GB12228-1989 General Valve Carbon Steel Forgings Technical Conditions
- GB/T 9131-2000 Steel Pipe Flange Pressure-Temperature Class
- GBT13927-2008 Industrial Valve-Pressure Test
- GBT1048-2019 Definition and Selection of Nominal Pressure of Piping Components

Steam Distribution Manifolds

When installing, it is recommended that the steam inlet is installed at the top, and the steam trap set at the bottom. It is best to recover the condensed water discharged from the trap group. If it is directly discharged into the atmosphere, it is recommended to install a silencer.

Condensate Manifolds

During installing, it is recommended that the condensate outlet is at the top, and the bottom should be installed with a shut-off valve for sewage discharge.

Material Table

Manifolds	CF8
Bonnet	CF8
Bellows Assembly	SS304
Stem	SS304
Valve Core	SS440C
Handwheel	SS304
Gasket	Flexible graphite

Structural Diagram

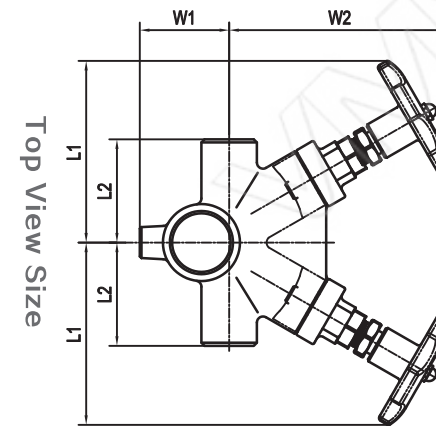

BSPM03 Size

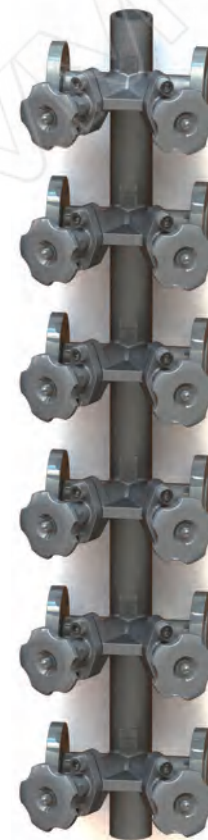
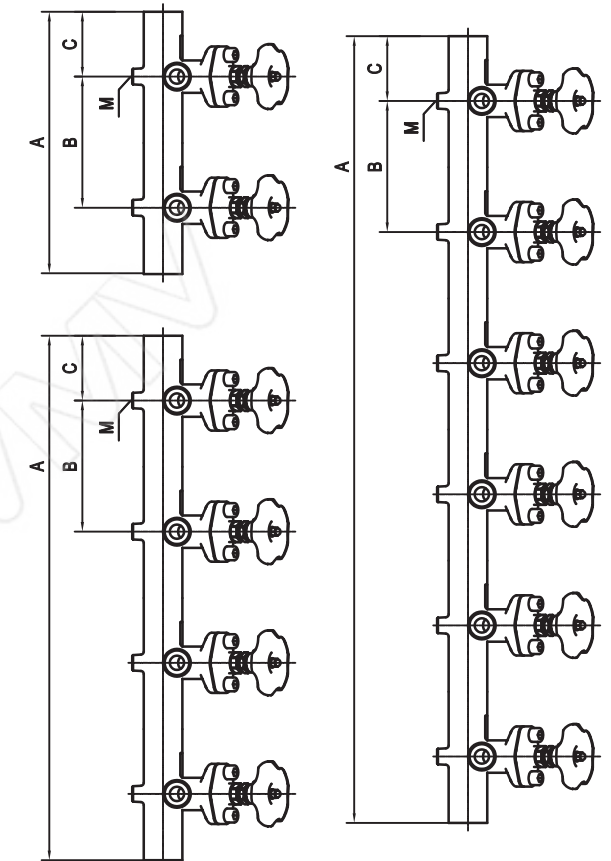

Structure Size Table

Product	Interface	Director	Manifold	Shape size							Weight	
				A	B	C	L1	L2	W1	W2	M	Kg
BSPM03-4	4	40	15/20	340	170	85	120	67	145	58	M12	9.2
BSPM03-6	6	40	15/20	510	170	85	120	67	145	58	M12	13.8
BSPM03-8	8	40	15/20	680	170	85	120	67	145	58	M12	18.5
BSPM03-10	10	40	15/20	850	170	85	120	67	145	58	M12	23.1
BSPM03-12	12	40	15/20	1020	170	85	120	67	145	58	M12	27.8

Unit(mm)

Technical Parameters

Nominal pressure	PN40/Class300
Max. allowable pressure (shell)	3.03Mpa/200°C
Max. allowable temperature (shell)	450°C/2.16MPa
Max. working pressure	2.56MPa
Max. operating temperature	350°C
Factory cold test pressure	6.0MPa
Air Seal test	2.0MPa

Notice

- During operation, the bellows globe valve should be fully opened or fully closed, and cannot be used for throttling.
- Do not use strong wrench to close the valve, preventing damage from the bellows caused by excessive torque.

Bellows Stainless Steel Steam Distribution Manifolds

Bellows Stainless Steel Condensate Collection Manifolds

Product Description

VMV's "Steam Distribution Manifolds" integrates all the components required for it (steam traps, manifolds, valves, etc.). All components are installed on the base bracket, and the manifolds are scientifically distributed on both sides to provide a compact, easy-to-disassemble centralized positioning assembly.

The Body is made of corrosion resistant material CF8, which is suitable for high-end manifolds, instruments, chemical corrosion-resistant pipes and pipeline heating. The instrument heating distribution pipes can be connected by ferrules.

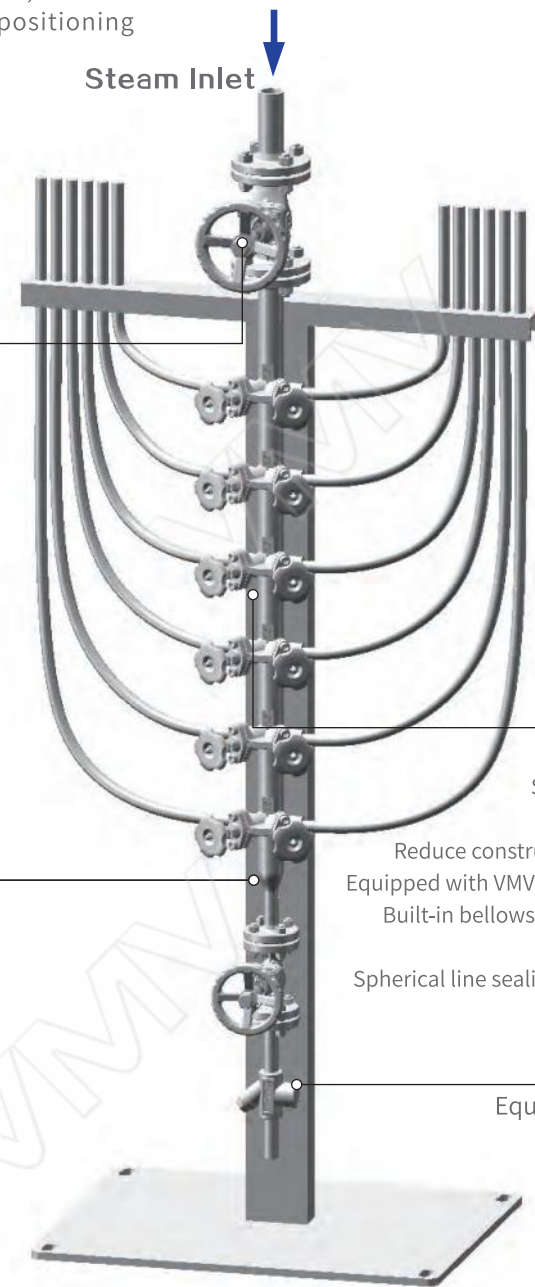

Bellows Sealed Globe Valve

- Equipped with bellows sealed globe valve for steam inlet
- Ensure zero leakage and maintenance free at the packing
- Line Sealed Seat
- Improve sealing performance
- Precision machined stainless steel handwheel
- Ergonomically designed

Manifolds Stainless Steel Material

Centralize all steam distribution valves
Standardized and integrated skid-mounted combination

Reduce construction time and cost for on-site installation
Equipped with VMV bellows sealed globe valve and steam trap
Built-in bellows sealed globe valve ensures zero leakage at packing
Spherical line sealing structure of valve core improves sealing

Steam Trap

Equipped with a steam trap at the bottom
Remove condensate

Manifolds Assembly Base

- Optional customized steel base and frame
- Manifolds on both sides for optimal installation sequencing
- Easy on-site installation

Product Description

VMV's "Condensate Manifold" integrates all components required for it (steam traps, manifolds, valves, etc.). All components are installed on the base bracket, and the manifolds are scientifically distributed on both sides to provide a compact, easy to disassemble centralized positioning assembly.

The Body is made of corrosion resistant material CF8, which is suitable for high-end manifolds, instruments, chemical corrosion-resistant pipes and pipeline heating. The instrument heating recovery pipes can be connected by ferrules.

Bellows Sealed Globe Valve

- Condensate outlet configuration
- Bellows sealed globe valve
- Ensure zero leakage at the packing
- Maintenance free
- Line Sealed Seat improves sealing performance
- Precision machined stainless steel handwheel

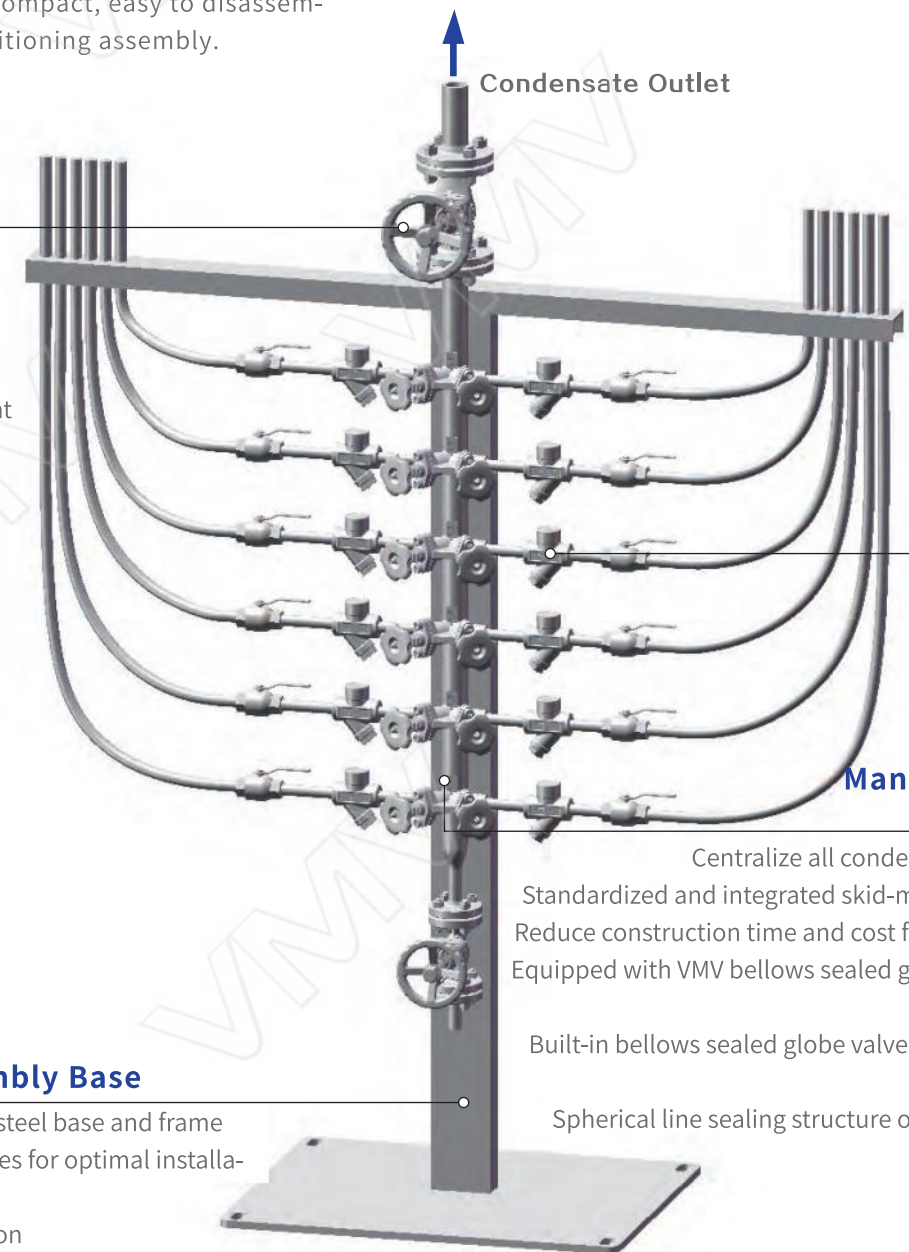

Steam Trap

Configure thermodynamic, thermostatic, bucket inverted and other types of steam traps

Manifold Stainless Steel Material

Centralize all condensate recovery valves
Standardized and integrated skid-mounted combination
Reduce construction time and cost for on-site installation
Equipped with VMV bellows sealed globe valve and steam trap

Built-in bellows sealed globe valve ensures zero leakage at packing

Spherical line sealing structure of valve core improves

Manifold Assembly Base

- Optional customized steel base and frame
- Manifolds on both sides for optimal installation sequencing
- Easy on-site installation

Bellows Forged Steel Manifolds

Bellows Forged Steel Manifolds

Product Description

VMV's "Bellows Forged Steel Manifolds" have built-in bellows sealed globe valves for steam distribution and condensate collection systems. Depending on the installation, BSPM and BCPM can be used for steam distribution or condensate collection.

The main body adopts the overall forging process material A105, which is dense and high in strength. Suitable for heat tracing of chemical pipelines. They are suitable for highend manifolds,instru-ments,chemical corrosion resistant pipes and pipeline heating.

Manifold Body

High strength and corrosion resistance
Temperature resistant up to 350°C
Integrated, compact structure

Handwheel

Integral molding of handwheel
made of die-cast aluminum material
Light weight and high strength
Beautiful and compact, good grip

Gland,Packing Gland

The packing compaction structure is
center-adjustable
Split gland,packing gland
Prevent valve stem from sticking

Valve Core, Valve Seat

Integral spherical valve core
Mating Conical Seat
Achieve linear sealing
Improve sealing performance
The valve core adopts martensitic
hardening treatment
Improve scour resistance

Bellows Assembly

Built-in stainless steel
bellows assembly
It and the graphite
packing realize the
double sealing guaran-
tee of the valve stem

Valve Bonnet

Special custom forged bonnet
High structural strength

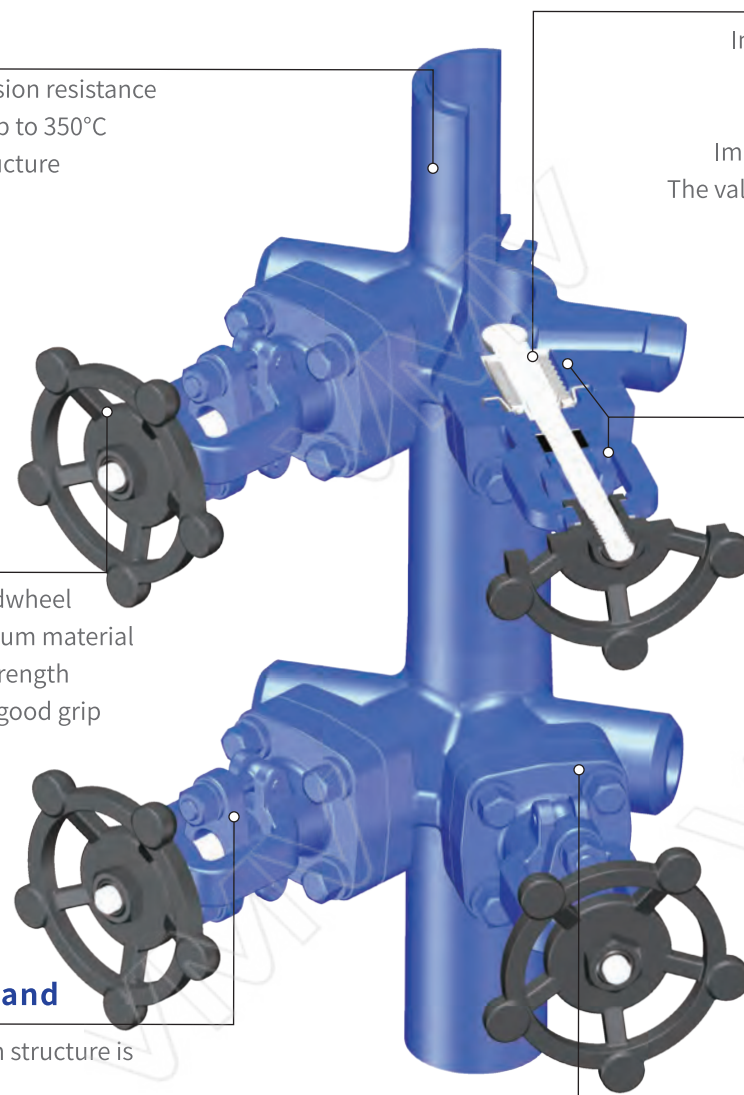

Technical Parameter

Nominal pressure	PN40/Class 300
Max. allowable pressure (shell)	3.92MPa/200°C
Max. allowable temperature (shell)	450°C/1.66MPa
Max. working pressure	4.0MPa
Max. operating temperature	350°C
Factory cold test pressure	6.0MPa
Air test	2.0MPa

Notice

During operation, the bellows sealed globe valve should be fully opened or fully closed, and cannot be used for throttling. Refuse to use an torque wrench to close the valve to prevent the bellows from being damaged by excessive torque.

Structural Features

- Integrated design, solid structure, shorten on-site construction time
- Maximize installation space saving and easy maintenance
- Integral ball core sealing surface and Stellite alloy hardened seat for perfect sealing
- Adopt stainless steel bellows design, durable,easy to open, eliminate leakage at the packing.

Technical Standard

- GB12224-1989 General Requirements For Steel Valves
- GB12228-1989 General Valve Carbon Steel Forgings Technical Conditions
- GB/T 9131-2000 Steel Pipe Flange Pressure-Tempera-Ture Class
- GBT13927-2008 Industrial Valve-Pressure Test
- GBT1048-2019 Definition and Selection of Nominal Pressure of Pipeling Components

Steam Distribution Manifolds

When installing, it is recommended that the steam inlet be installed at the top and the steam trap set the bottom. It is best to recover the condensate water discharged from the steam trap group. If it is directly discharged into the atmosphere, it is recommended to install a silencer.

Condensate Collection Manifolds

During installation, it is recommended that the top be the condensate outlet, and the bottom should be installed with a shut-off valve for sewage discharge.

Material Table

Manifolds Body	A105
Bonnet	A105
Bellows Assembly	SS304
Stem	SS304
Valve Core	SS440C
Handwheel	SS304
Gasket	Flexible Graphite

Bellows Forged Steel Steam Distribution Manifolds

Bellows Forged Steel Steam Distribution Manifolds

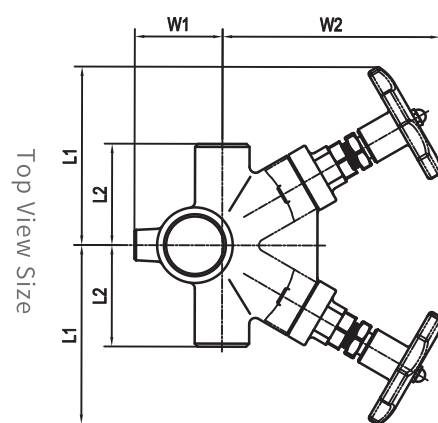

BSPM02 Size

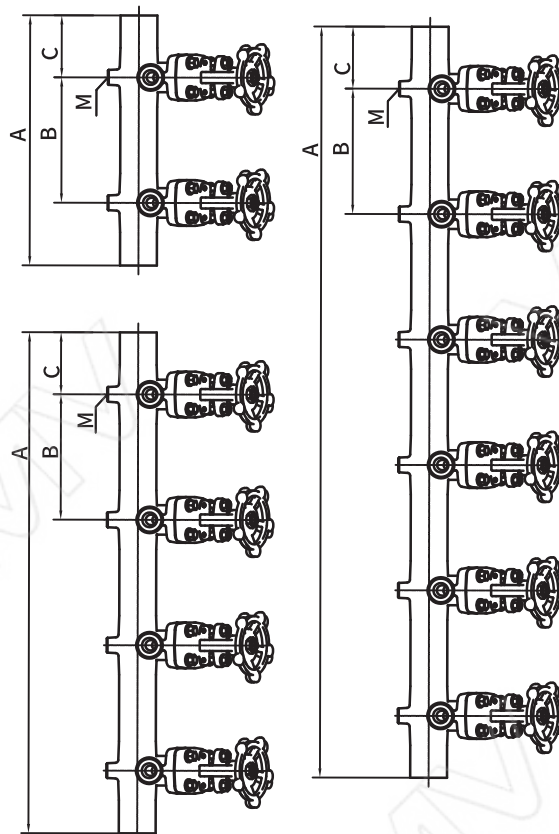

Product Description

VMV's "Steam Distribution Manifolds" integrates all the components required for it (steam traps, manifolds, valves, etc). All components are installed on the base bracket, and the manifolds are scientifically distributed on both sides to provide a compact, easy-to-disassemble centralized positioning assembly.

The Body is made of forged carbon steel material A105, the main body is dense, and it is suitable for high pressure chemical pipelines and pipeline heating.

Bellows Sealed Globe Valve

The steam inlet is equipped with bellows sealed globe valve
Ensure zero leakage and maintenance free at the packing
Linear sealing seat improves sealing performance

Manifolds Body Forged Carbon Steel

- Centralize all steam distribution valves
- Standardized and integrated skid-mounted combination
- Reduce construction time and cost for on-site installation
- Equipped with VMV bellows sealed globe valve and steam trap
- Built-in bellows sealed globe valve ensures zero leakage at packing
- Spherical line sealing structure of valve core improves sealing performance

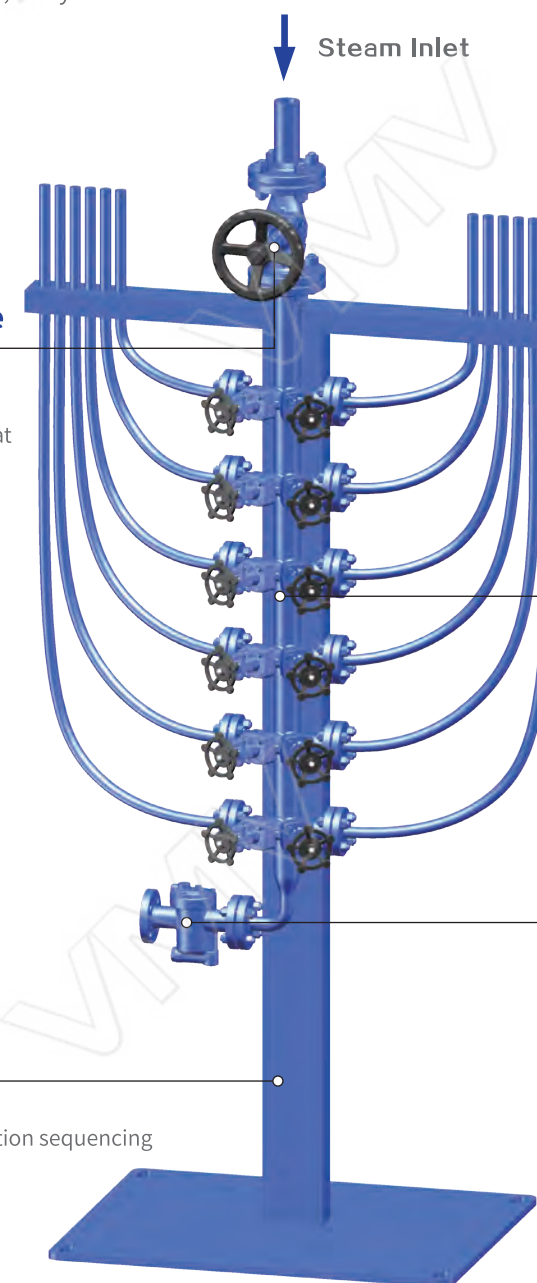

Steam Traps

Bottom equipped with steam trap
Discharges condensate water

Manifolds Assembly Base

Optional customized steel base and frame
Manifolds on both sides for optimal installation sequencing
Easy on site installation



BSPM03-12

Structure Size Table

Product	Interface	Director	Manifold	Shape Size								Weight	
				Model	QTY	Size	Size	A	B	C	L1		L2
BSPM02-4	4	40	15/20		340	170	85	135	75	168	58	M12	10.5
BSPM02-6	6	40	15/20		510	170	85	135	75	168	58	M12	15.8
BSPM02-8	8	40	15/20		680	170	85	135	75	168	58	M12	21.2
BSPM02-10	10	40	15/20		850	170	85	135	75	168	58	M12	26.5
BSPM02-12	12	40	15/20		1020	170	85	135	75	168	58	M12	31.8

Unit(mm)

Bellows Forged Steel Condensate Collection Manifolds

Bellows Forged Steel Condensate Collection Manifolds

Product Description

VMV's "Condensate Manifold" integrates all components required for it (steam traps, manifolds, valves, etc.). All components are installed on the base bracket, and the manifolds are scientifically distributed on both sides to provide a compact, easy to disassemble centralized positioning assembly.

The Body is made of forged carbon steel material A105, the main body is dense, and it is suitable for high-pressure chemical pipelines and pipe-line heating.

Bellows Sealed Globe Valve

- Condensate outlet equipped with a bellows sealed globe valve
- Ensure zero leakage at the packing
- Linear sealing seat improves sealing performance
- Precision machined stainless steel handwheel
- Maintenance free
- Ergonomically Design

Manifolds Body Forged Carbon Steel

- Centralize all condensate recovery valves
- Standardized and integrated skid-mounted combination
- Reduce construction time and cost for on-site installation
- Equipped with VMV bellows sealed globe valve and steam trap
- Built-in bellows sealed globe valve ensures zero leakage at packing
- Spherical line sealing structure of valve core improves sealing performance

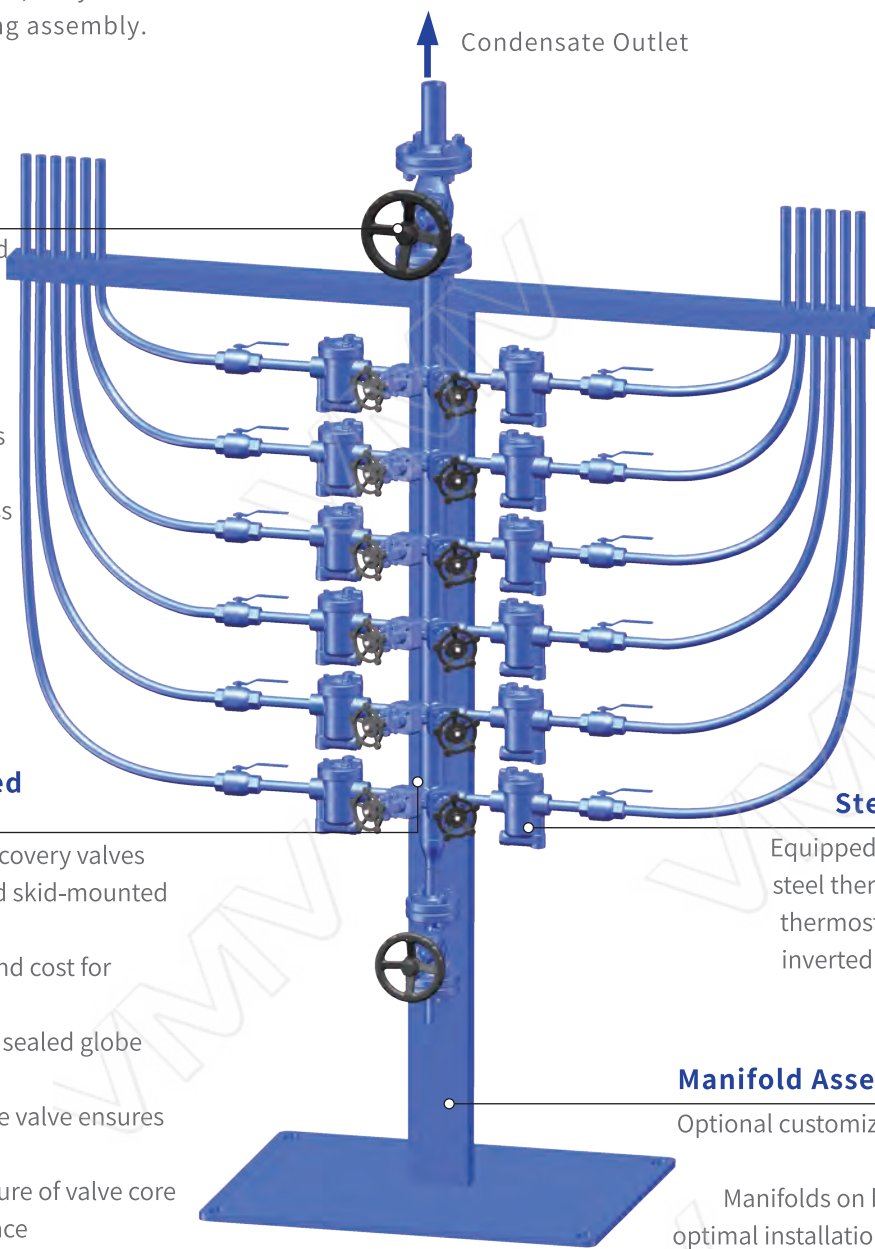

Steam Traps

Equipped with carbon steel thermodynamic, thermostatic, bucket inverted steam traps.

Manifold Assembly Base

Optional customized steel base and frame
Manifolds on both sides for optimal installation sequencing
Easy on-site installation

Stainless Steel Steam Trap Combination

Equipped with stainless steel bucket inverted steam trap and stainless steel steam trap station, (Front and rear stainless steel globe valve, stainless steel filter, check valve)

Fully enclosed, vibration-proof shell
Small, lightweight traps
Freeze-resistant, no damage
Super anti-corrosion performance

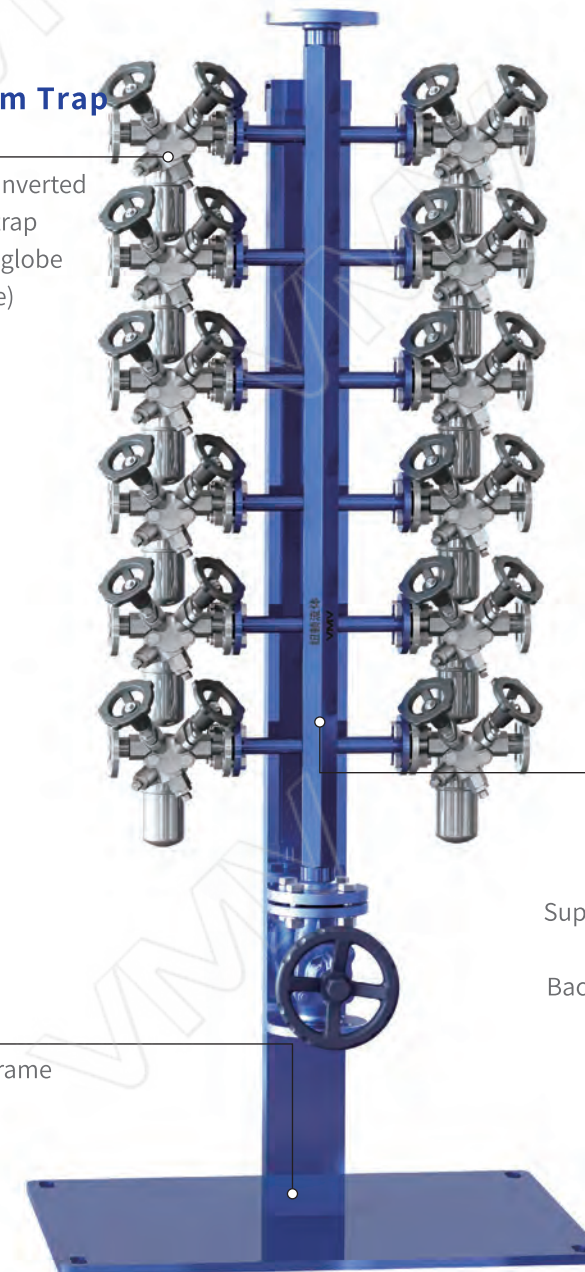

Manifolds Body Forged Steel Material

A105 forged steel material
Hexagonal steel pipe design
Fully consider corrosion allowance
Super strong siphons inside the manifolds form water seal
Back pressure recovers condensate at low points in the pipeline

Manifold Assembly Base

Optional customized steel base and frame
Manifolds on both sides for optimal installation sequencing
Easy on site installation

BCPM03-12

STEAM&HEAT TRANSFER OIL CONTROL VALVE

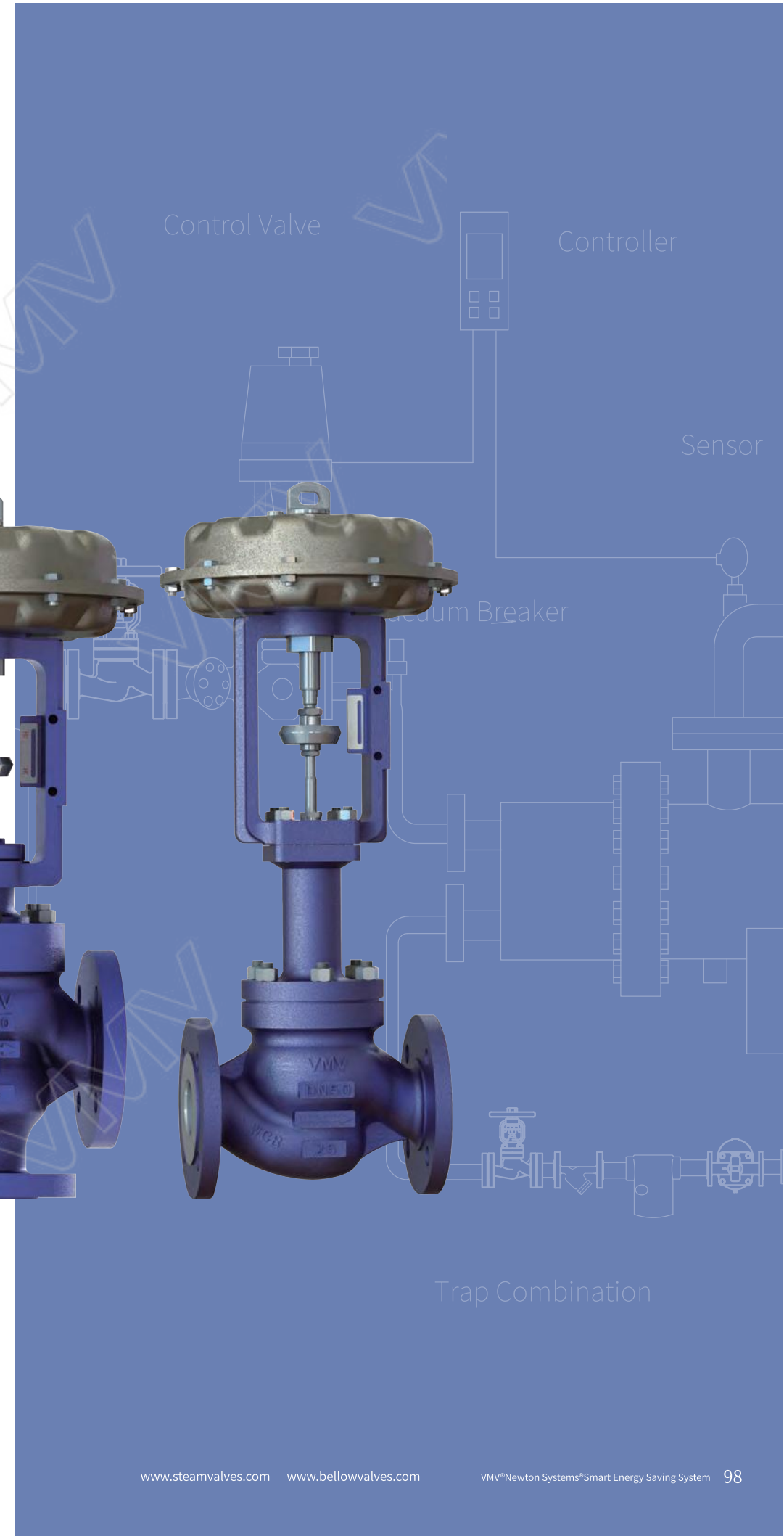

V8000 Series Control Valve

V8000Series Control Valve

Product Description

VMV V8000 series control valve is a straight through structure, with the advantages of high adjustment accuracy, good stability, fast response speed, easy on-site maintenance, etc., and also can be used in cavitation, flash, easy to scour and other special conditions, can meet the requirements of most working conditions. It can be equipped with multi-spring film actuator or electric actuator.

Technical Parameters and Performance

Technical Parameters and Performance						
Body	Body type	Straight-through type				
	Nominal pressure	PN16	PN25	PN40	JIS/KS10	JIS/KS20
	Connection	Connection type	BW	RF, MFM		
		Flange distance	Refer to the size table			
Body material		WCB	WC5	CF8	CF8M	
		WC6	WC9	CF3M	CF3	
Bonnet type		Normal temperature		Heat sink type	Bellows type	
		-17~+250°C		+250~+538°C	-17~+400°C	
Packing material		PTFE V-type packing		Flexible graphite packing		
Plug	Plug type	Unbalanced single seat		Balanced single seat	Balanced double seat	
	Flow characteristic	Equal percentage		Linear	Quick opening	
	Plug material	Base material	410/CA15		304	316L
Surface treatment material		Heat treatment		Surfacing STL/ surface nitriding	Surfacing STL/ surface nitriding	
Actuator	Drive source	Compressed air(pneumatic)		220V/380V Power supply (electric)		
	Model	MT series		Please consult sales		
	Supply air pressure	≥ 400KPa				
	Ambient temperature		-30 ~ +70°C	-30 ~ -40°C		
		Standard equipped		Low temperature type		
Valve Action Type		Air-on		Air-close		
		Air pressure increase valve open		Air pressure increase valve close		
Accessory	Positioner	Air filter pressure reducing valve	Speed up relay	Lock-up valve	Limit switch	Handwheel
	Surface painting	Blue paint, clients specified color painting, and stainless steel valve body material can be left unpaint-coat				
Painting Special requirements		Degreasing and non-oiling	Water removal	Copper-free		
	Leakage Class		IV	V	VI	
		Hard seal standard	Be available	Soft seal(RPTFE/PTTK)		

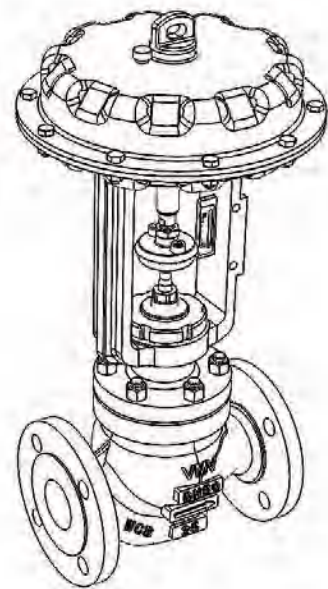

Pneumatic conventional structure

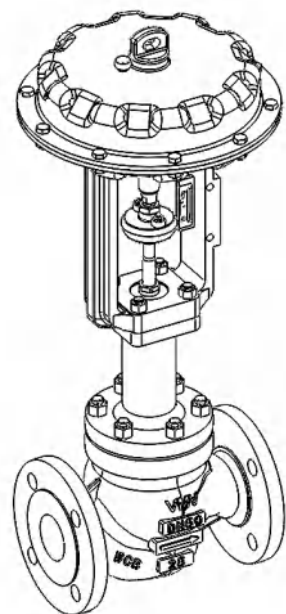

Pneumatic bellows conventional structure

Valve body structure

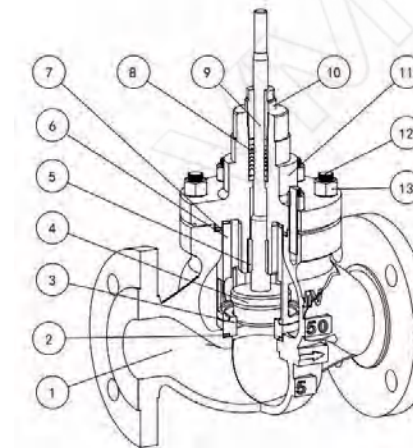

Conventional control valve

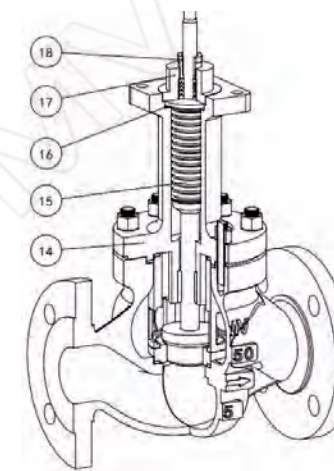

Bellows control valve

Conventional balanced control valve structure (for other structures, please consult VMV)

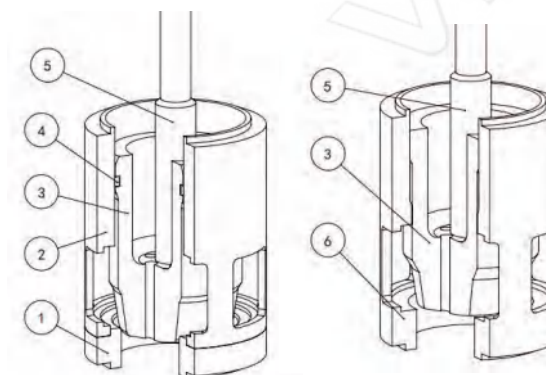

Balanced single-seat structure Balanced double-seat structure

Technical parameter

No.	Name	Material
1	Body	Cast steel/Stainless steel
2	Seat gasket	304+ Graphite/316L+ Graphite
3	Shunt lower cage	410/316L+ hardening
4	Seat gasket	304+ Graphite/316L+ Graphite
5	Shunt upper cage	410/316L+ hardening
6	Shunt plug	410/316L+ hardening
7	Bonnet gasket	304+ Graphite/316L+ Graphite
8	Guide bearing	Stainless steel + hardening
9	Stem	630/316L
10	Regular valve bonnet	Carbon steel/Stainless steel
11	Packing assembly	PTFE/ Flexible graphite
12	Bolt	B7/B8
13	Nut	2H/8

Technical parameter

No.	Name	Material
14	Bellows bonnet	Carbon steel/Stainless steel
15	Bellows assembly	304/316L
16	Bellows gasket	304+ Graphite/316L+ Graphite
17	Packing box	304/316L
18	Packing gland	304

Technical parameter

No.	Name	Material
1	Seat	410/316L+ hardening
2	Cage	410/316L+ hardening
3	Plug	410/316L+ hardening
4	Piston ring	PTFE/ Graphite/Stainless steel
5	Stem	630/316L
6	Cage	410/316L+ hardening

V8000 Series Control Valve

V8000 Series Control Valve

CV value of control valve

Nominal size	Seat diameter code	Equal percentage CV	Linear CV	Nominal size	Seat diameter code	Equal percentage CV	Linear CV
DN15	6E	-	0.01	DN32	32	18.7	18.7
DN15	6D	-	0.08	DN40	40	29	29
DN15	6C	-	0.12	DN50	50	42	42
DN15	6B	-	0.23	DN65	65	74	74
DN15	6A	-	0.58	DN80	80	117	117
DN15	7	1.2	1.2	DN100	100	187	187
DN15	8	1.9	1.9	DN125	125	287	304
DN15	10	2.9	2.9	DN150	150	433	456
DN15	15	4.7	4.7	DN200	200	678	749
DN20	20	7.4	7.4	DN250	250	819	913
DN25	25	11.7	11.7	DN300	300	1170	1287

Size of control valve body

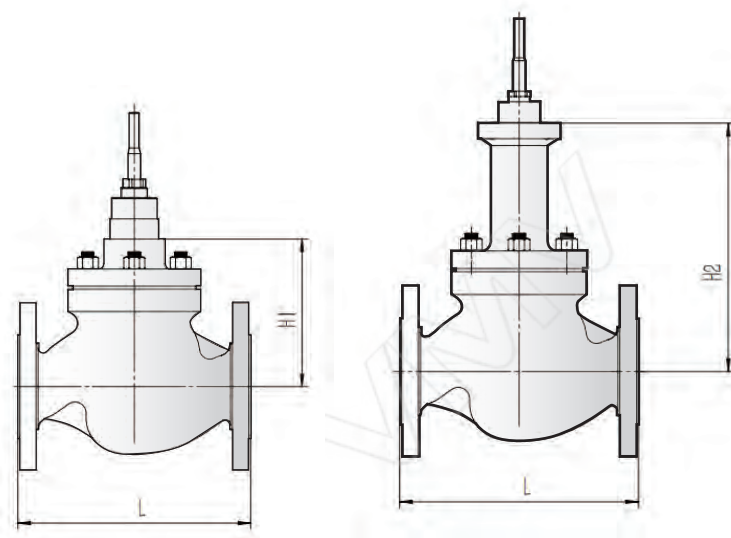

Nominal size	L	L1	H1	H2
DN15	130	90	115	240
DN20	150	95	115	240
DN25	160	100	115	240
DN32	180	105	140	270
DN40	200	115	140	270
DN50	230	125	180	270
DN65	290	145	210	370
DN80	310	155	210	370
DN100	350	175	221	390
DN125	400	200	260	550
DN150	480	225	260	570
DN200	600	275	330	640

Control valve model

No.	Name	Code	Code description	Selection case
1	Valve series	V8000	Straight control valve	V8000
2		-		-
3	Valve structure	DB	Unbalanced single seat	DB
		DP	Balanced single seat	
		SP	Balanced double seat	
		DZ	Low noise plug	
		DJ	Multistage pressure relief plug	
		XD	Pilot operated plug	
4		MG	Labyrinth plug	-
		-		
5	Nominal size	1	DN25(NPS1)	1
		
		12	DN300(NPS12)	
6		x		x
		-		
7	Nominal pressure	25	PN25	25
		150	Class150	
8	Connection method	RF	RF flange ends	RF
		FM	FM flange ends	
		BW	Butt welding	
		RC	Threaded connection	
9		-		-
		WCB	Cast steel	
10	Body material	WC9	Alloy steel	WCB
		C5	Alloy steel	
		CF8	304 stainless steel	
		CF8M	316 stainless steel	
11	Valve cap type	-		-
		P	Standard	
		H	Heat sink	
12		B	Bellows	P
		-		
13	Stem sealing	P	PTFE	P
		S	Graphite	
14		-		-
		-		
15	Valve trim	LXXXX	Linear plug (XXXX represents the CV value)	P11.7
		PXXXX	Equal percentage plug(XXXX represents the CV value)	
16		-		-
		FC	Fail-close	
		FO	Fail-open	
17	Fault location	FL	Fault location	FC
		-		
18		-		-
19	Actuator model			MT2R

Selection case:V8000-DB-1X25RF-WCB-PP-P11.7-FC-MT2R

V6000 Series Three-way Control Valve

V6000 Series Three-way Control Valve

Product Description

V6000 series three-way control valve, divided into three-way separating and three-way mixing flow. The main function is to divide an imported fluid into two export fluids, or to synthesize two imported fluids into an export fluid, which can replace two straight control valves, mainly applied for hot oil, steam, condensate, air and other fluid regulation conditions; It has the advantages of high adjustment precision, good stability, fast response speed, easy on-site maintenance, etc. It can be equipped with multi-spring film actuator or electric actuator.

CV value of control valve Technical Parameters and Performance

Nominal size	Seat diameter code	Rated CV	
		Three-way shunt	Three-way confluence
DN15	15	-	4.7
DN20	20	-	7.4
DN25	25	11.7	11.7
DN32	32	19.8	19.8
DN40	40	29	29
DN50	50	42	42
DN65	65	74	74
DN80	80	117	117
DN100	100	151	151
DN125	125	226	226
DN150	150	360	360
DN200	200	522	522

Technical Parameters and Performance						
Body	Body type	Straight-through type				
	Nominal pressure	PN16	PN25	PN40	JIS/KS10	JIS/KS20
	Connection	Connection type	BW	RF, MFM		
		Flange distance	Refer to the size table			
	Body material		WCB	WC5	CF8	CF8M
		WC6	WC9	CF3M	CF3	
Bonnet type		Normal temperature		Heat sink type	Bellows type	
		-17~+250°C		+250~+538°C	-17~+400°C	
	Packing material	PTFE V-type packing		Flexible graphite packing		
Plug	Plug type	Separating flow structure		Mixing flow structure		
	Flow characteristic	Linear				
	Plug material	Base material	410/CA15	304	316L	
Base material		Heat treatment	Surfacing STL/ surface nitriding	Surfacing STL/ surface nitriding		
Actuator	Drive source	Compressed air (pneumatic)		220V/380V Power supply (electric)		
	Model	MT series		Please consult sales		
	Supply air pressure	≥ 400KPa				
	Ambient temperature		-30 ~ +70°C	-30 ~ -40°C		
		Standard equipped	Low temperature type			
Valve action type		Air-on		Air-close		
		Air pressure increase valve open		Air pressure increase valve close		
Accessory	Positioner	Air filter pressure reducing valve	Speed up relay	Lock-up valve	Limit switch	
	Handwheel					
Painting	Surface painting	Blue paint, clients specified color painting, and stainless steel valve body material can be left unpaint-coat				
	Special requirements	Degreasing and non-oiling	Water removal	Copper-free		
Leakage Class		IV	V	VI		
		Hard seal standard	Be available	Soft seal (RPTFE/PTTK)		

Valve body structure

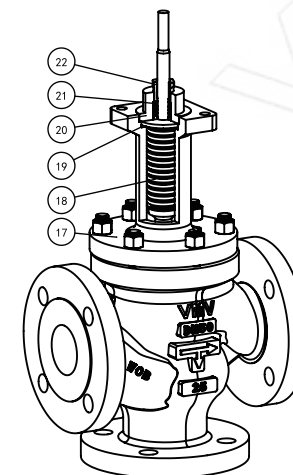
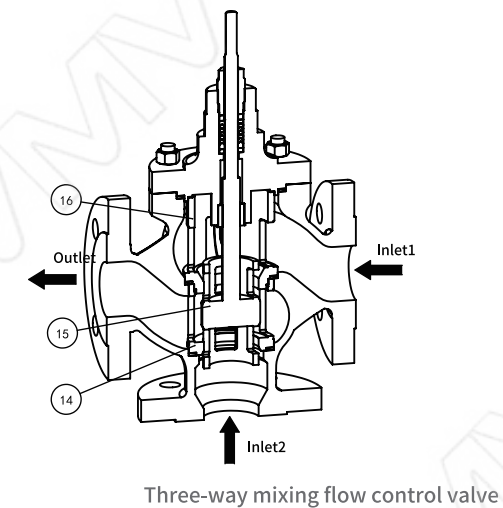
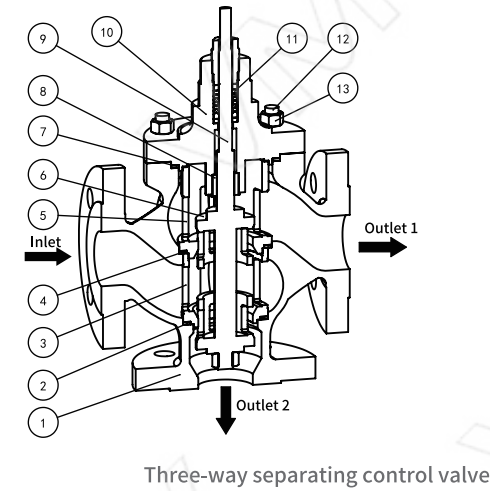

Technical Parameters

No.	Name	Material
1	Body	Cast steel/Stainless steel
2	Seat gasket	304+ Graphite/316L+ Graphite
3	Separating lower cage	410/316L+ hardening
4	Seat gasket	304+ Graphite/316L+ Graphite
5	Separating upper cage	410/316L+ hardening
6	Separating plug	410/316L+ hardening
7	Bonnet gasket	304+ Graphite/316L+ Graphite
8	Guide bearing	Stainless steel + hardening
9	Stem	630/316L
10	Regular valve bonnet	Cast steel/Stainless steel
11	Packing assembly	PTFE/ Flexible graphite
12	Bolt	B7/B8
13	Nut	2H/8

Technical Parameters

No.	Name	Material
14	Mixing lower cage	410/316L+ hardening
15	Mixing plug	410/316L+ hardening
16	Mixing upper cage	410/316L+ hardening

Technical Parameters

No.	Name	Material
17	Bellows bonnet	Cast steel/Stainless steel
18	Bellows assembly	304/316L
19	Bellows gasket	304+ Graphite/316L+ Graphite
20	Packing box	304/316L
21	Packing assembly	PTFE/ Flexible graphite
22	Packing gland	304

V6000 Series Three-way Control Valve

V6000 Series Three-way Control Valve

Size of control valve body

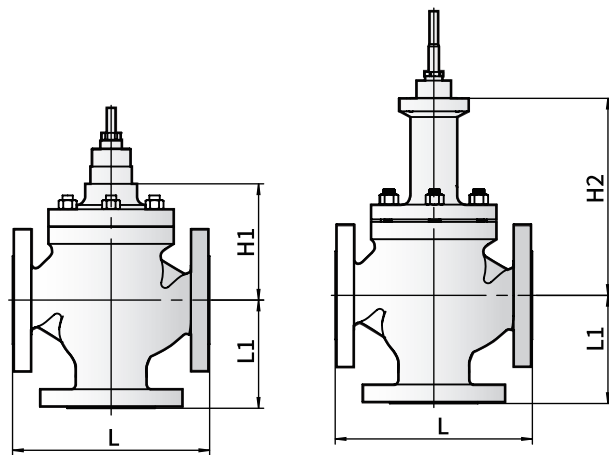

Nominal size	L	L1	H1	H2
DN15	130	90	115	240
DN20	150	95	115	240
DN25	160	100	115	240
DN32	180	105	140	270
DN40	200	115	140	270
DN50	230	125	180	270
DN65	290	145	210	370
DN80	310	155	210	370
DN100	350	175	221	390
DN125	400	200	260	550
DN150	480	225	260	570
DN200	600	275	330	640

WCB/A105 material PN16
Valve body pressure-temperature ratings

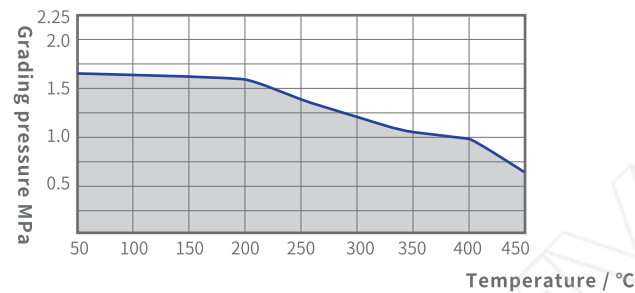

WCB/A105 material PN25
Valve body pressure-temperature ratings

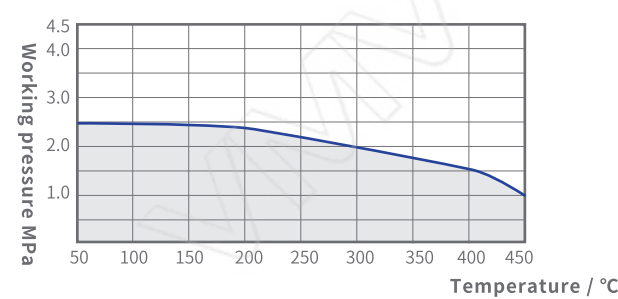

WCB/A105 material PN40
Valve body pressure-temperature ratings

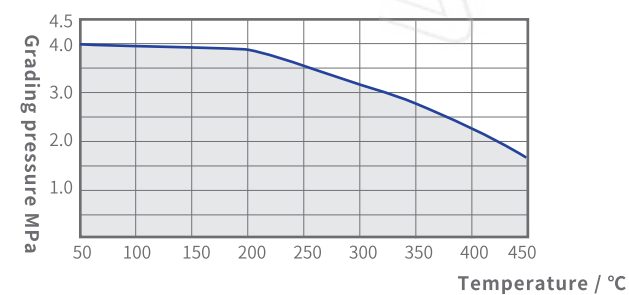

WCB/A105 material PN63
Valve body pressure-temperature ratings

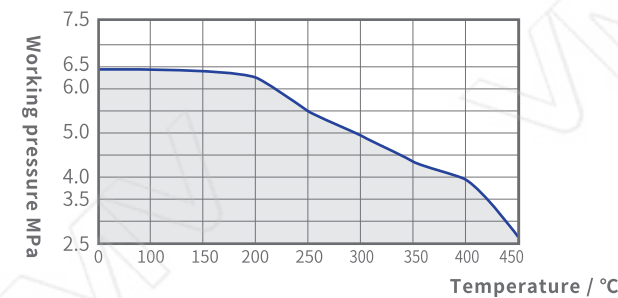

V6000 series three-way control valve

No.	Name	Code	Code description	Selection case
1	Valve series	V6000	Three way control valve	V6000
2		-		-
3	Valve structure	SF	Separating	SF
		SH	Mixing	
4		-		-
5	Nominal size	1	DN25(NPS1)	1
		
		8	DN200(NPS8)	
6		x		x
7	Nominal pressure	25	PN25	25
		150	Class150	
8	Connection method	RF	RF flange ends	RF
		FM	FM flange ends	
		BW	Butt welding	
		RC	Threaded connection	
9		-		-
10	Body material	WCB	Cast steel	WCB
		WC9	Alloy steel	
		C5	Alloy steel	
		CF8	304 Stainless steel	
		CF8M	316 Stainless steel	
11		-		-
12	Valve cap type	P	Standard	P
		H	Heat sink	
		B	Bellows	
13	Stem sealing	P	PTFE	P
		S	Graphite	
14		-		-
15	Valve trim	LXXXX	Linear plug (XXXX represents the CV value)	L11.7
16		-		-
17	Fault location	FC	Fail-close(The bottom channel of the mixed structure is closed, and the bottom channel of the separating structure is fully opened)	FC
		FO	Fail-open(The bottom channel of the mixed structure is fully open, and the bottom channel of the separating structure is closed)	
		FL	Fault location	
18		-		-
19	Actuator model			MT2R

Selection case:V6000-SF-1X25RF-WCB-PP-P11.7-FC-MT2R

Steam Piping Accessories

The piping system must be equipped with bellows sealed globe valves, filters, check valves, mixers, vacuum breakers, steam water separators, sight glasses.

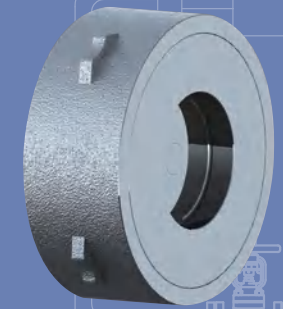
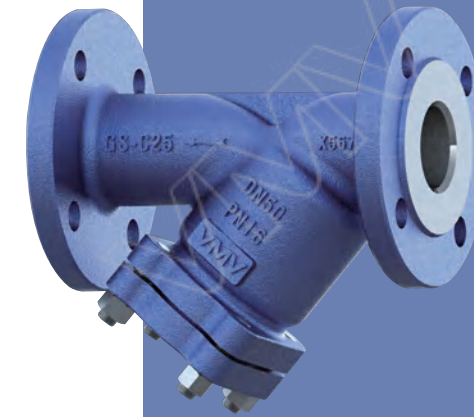

Control Valve

Controller

Sensor

Vacuum Breaker

Trap Combination

Bellows Sealed Globe Valve

Bellows Sealed Globe Valve



Conical sealing: No impurities remain on the sealing surface. When it tends to close, the sealing surface has a self-cleaning effect to achieve linear sealing.



Balanced disc seal: After the small disc relieves the pressure, it drives the large disc to open easily.



Flat soft seal: The soft seal surface can prevent sparks when opening and closing, and is suitable for gaseous media or working conditions with corrosion resistance requirements.

Structural Features

- The mechanical properties of the castings are good, more than 98% are free of defects such as pores, blisters and cracks, and the effective wall thickness reaches the standard.
- The valve adopts conical sealing design and no impurities remain on the sealing surface. When it tends to close, the sealing surface has a self-cleaning effect. The conical sealing surface can amplify the axial force of the valve stem into the sealing force, and has better performance.

- Double sealing design of bellows and packing, with double guarantee, making the sealing at the valve stem safer and more reliable.
- Bellows are 100% tested for fugitiveness according to ISO15848 Class A standard; all bellows components and valves are 100% tested to Standard Class A to ensure zero leakage.
- Various disc designs can be provided according to working conditions, such as throttling disc, regulating disc, flat soft sealing disc, globe check valve disc, etc.

Technical Specifications

Design standard: EN12516, GB/T12224, GB/T12235
 F to F Dim: EN558, GB/T12221
 Flange ends: EN1092-1, GB/T9113
 Test inspection: EN12266, GB/T26480

Applicable Media

Steam, hot and cold water, oil, biphenyl, fatty acid, liquid ammonia, ammonia gas, natural gas, etc.

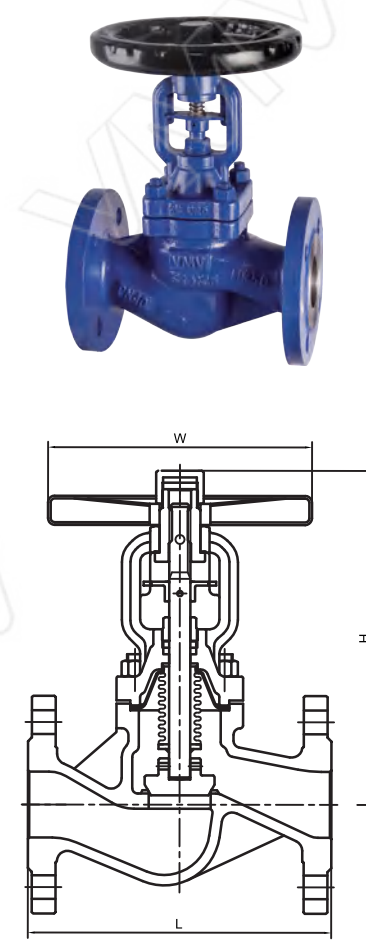
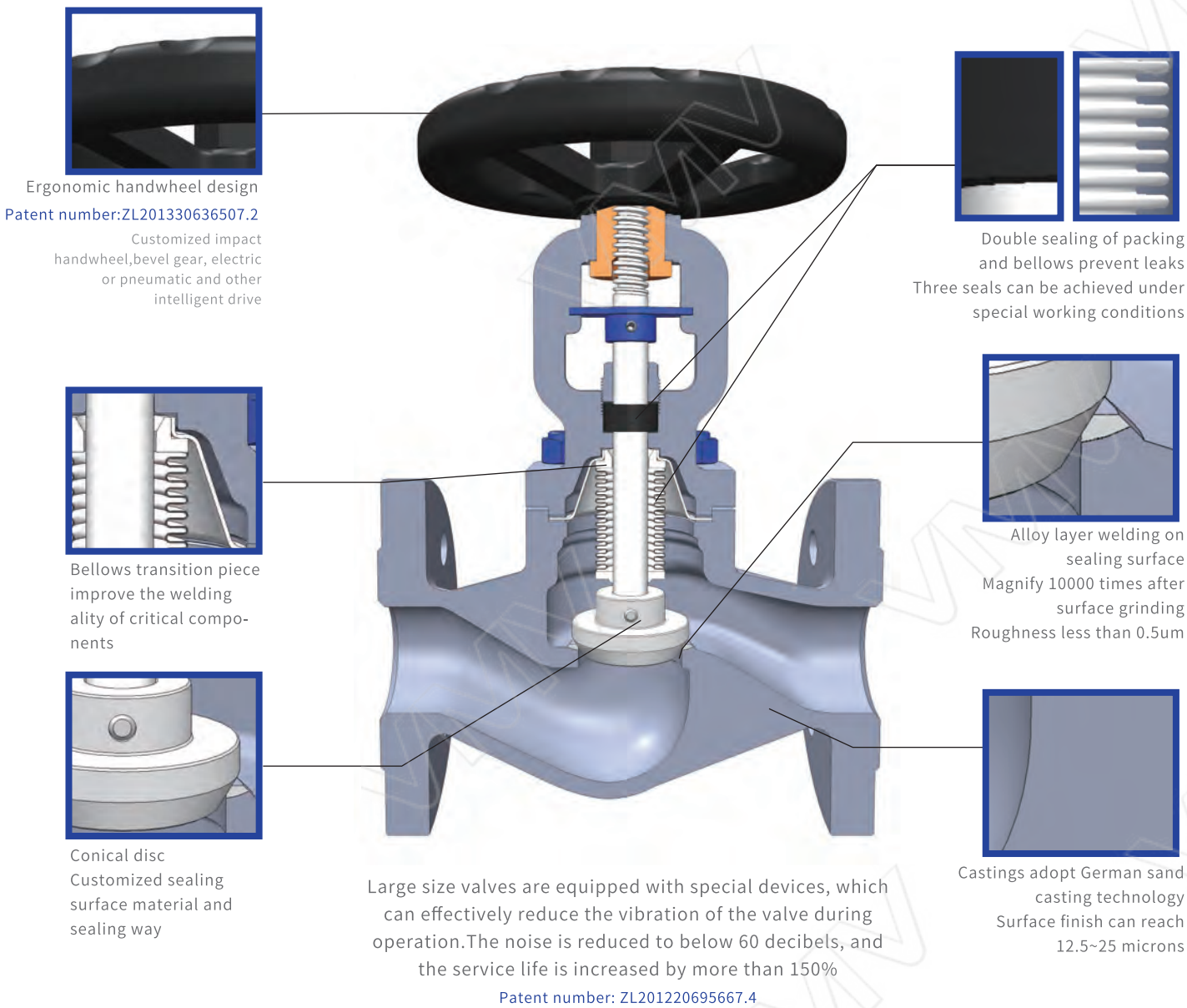

Data Size Table

Size DN	PN16			PN25			PN40		
	Length L	Hand wheel W	Center high H	Length L	Hand wheel W	Center High H	Length L	Hand wheel W	Center High H
15	130	φ140	192	130	φ140	192	130	φ140	192
20	150	φ140	192	150	φ140	192	150	φ140	192
25	160	φ160	207	160	φ160	207	160	φ160	207
32	180	φ160	207	180	φ160	207	180	φ160	207
40	200	φ180	245	200	φ180	245	200	φ180	245
50	230	φ200	253	230	φ200	253	230	φ200	253
65	290	φ220	295	290	φ220	295	290	φ220	295
80	310	φ250	328	310	φ250	328	310	φ250	328
100	350	φ300	385	350	φ300	385	350	φ300	385
125	400	φ350	427	400	φ350	427	400	φ350	427
150	480	φ400	480	480	φ400	480	480	φ400	480
200	600	φ450	672	600	φ450	672	600	φ450	672
250	730	φ550	775	730	φ550	775	730	φ550	775
300	850	φ600	852	850	φ600	852	850	φ600	852
350	980	φ700	1005	980	φ700	1005	980	φ700	1005
400	1100	φ700	1140	1100	φ700	1140	1100	φ700	1140

Bellows Sealed Gate Valve

Bellows Sealed Gate Valve

For bellows sealed gate valve, its key component metal bellows, the lower end is welded with the valve stem, and the upper end is welded with the connecting plate, forming a metal barrier between the medium and the atmosphere, ensuring zero leakage of the valve stem.

All bellows are 100% tested for fugitiveness according to ISO15848 Class A standard; all bellows components and valves are 100% tested to standard Class A to ensure zero leakage.



Welding of bellows components: Microcomputer controls the welding speed to ensure the quality of critical components

Structural Features

- Bellows sealed gate valve, its key component metal bellows, the lower end and the valve stem assembly are automatically welded, and the upper end and the connecting plate are automatically welded, forming a metal barrier between the fluid medium and the atmosphere to ensure zero leakage of the valve stem.
- Double sealing design of bellows and packing, with double insurance, making the sealing at the valve stem safer and more reliable.

- All bellows are 100% tested for fugitiveness according to ISO15848 Class A standard; all bellows components and valves are 100% tested to Standard Class A to ensure zero leakage.
- The valve cover has its own grease fitting, which can directly lubricate the valve stem, nut and bushing, unlike the traditional lubricating oil only on the thread.
- Ergonomic handwheel design. Electric or pneumatic intelligent drive, impact handwheel, bevel gear can be customized.

Technical Specifications

Design standard: EN12516, GB/T12224, GB/T12234
 F to F Dim: EN558, GB/T12221
 Flange ends: EN1092-I, GB/T9113
 Test inspection: EN12266, GB/T26480

Applicable Media

Steam, hot and cold water, oil, biphenyl, fatty acid, liquid ammonia, ammonia gas, natural gas, etc.

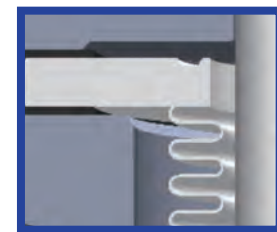

Automatic welding of upper end and connecting plate



Customized impact handwheel, bevel gear, electric or pneumatic and other intelligent drive.



Double sealing design of bellows and packing, with double guarantee, making the sealing at the valve stem safer and more reliable.



Multi-layer bellows, with guiding structure to prevent instability

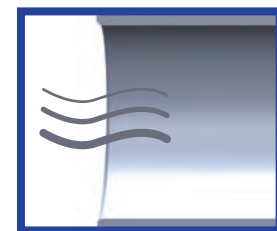

Full bore, high flow rate, zero flow resistance

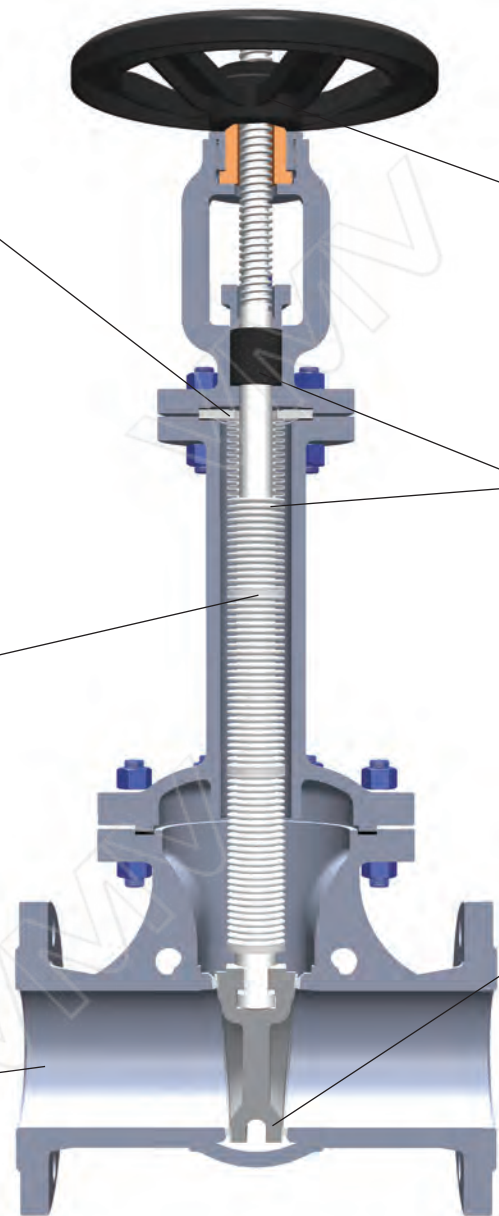

Large size valves adopts elastic gate plate Micro-elastic deformation gate makes sealing more secure plate.

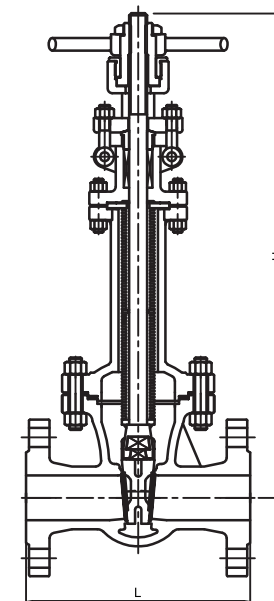

Data Size Table

Size DN	PN16			PN25			PN40		
	Length L	Hand wheel W	Center High H	Length L	Hand wheel W	Center High H	Length L	Hand wheel W	Center High H
40	200	φ200	435	200	φ200	435	200	φ200	435
50	250	φ220	500	250	φ220	500	250	φ220	500
65	270	φ240	560	270	φ240	560	270	φ240	560
80	280	φ280	620	280	φ280	620	280	φ280	620
100	300	φ300	800	300	φ300	800	300	φ300	800
125	325	φ320	900	325	φ320	900	325	φ320	900
150	350	φ350	1105	350	φ350	1105	350	φ350	1105
200	400	φ400	1385	400	φ400	1385	400	φ400	1385
250	450	φ450	1600	450	φ450	1600	450	φ450	1600
300	500	φ500	1950	500	φ500	1950	500	φ500	1950
350	550	φ550	2250	550	φ550	2250	550	φ550	2250
400	600	φ600	2550	600	φ600	2550	600	φ600	2550
450	650	φ650	2760	650	φ650	2760	650	φ650	2760
500	700	φ700	3150	700	φ700	3150	700	φ700	3150
600	800	φ750	3900	800	φ750	3900	800	φ750	3900

Vacuum Breaker

Vacuum Breaker

VMV vacuum breaker protect your equipment from vacuum damage and help to efficiently discharge condensate from pipelines and containers.

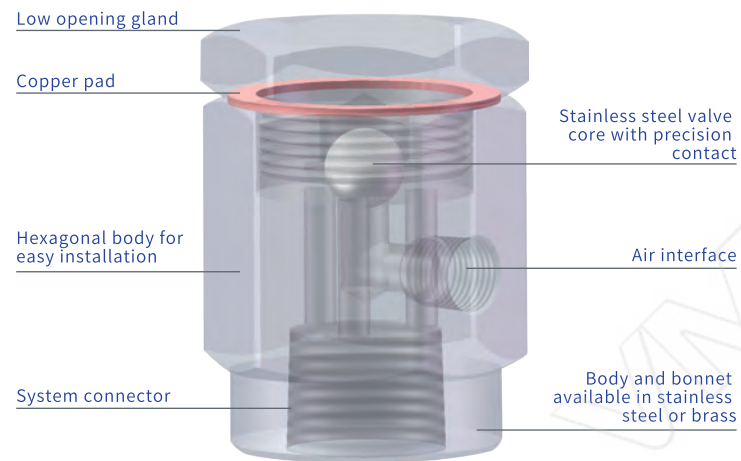

Working Principle

When working fine

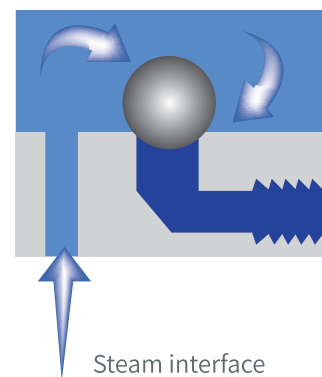

The high and precision valve core valve seat adopt linear seal design. When the pipeline is under pressure, the valve seat and valve core is tightly closed, and there is no steam leakage.

When vacuum occurs

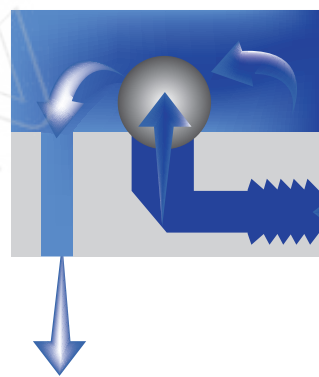

When the pressure of the steam system drops to normal pressure, the steam in the equipment cools down, and the valve core opens when a negative pressure is generated and a vacuum state occurs.

Air entering

※The differential pressure at which the valve opens is 4.6 mmHg

Technical Parameter

Working medium	steam, air	Max. allowable temperature	425°C
Nominal pressure	2.5MPa	Max. air intake	9000m ³ /h
Max. working pressure	2.1MPa	Noload leak rate	0.1%
Max. pressure	0.01MPa	Connection method	RC

Application

This product is robust and reliable and can be used in a variety of systems and equipment to prevent vacuum, such as:

- Heat exchanger
- Steam storage tank
- Boiler
- Jacketed pot
- Sterilization room
- Steam main line

Advantage

- Protects expensive equipment from vacuum damage
- Small size and sensitive action
- Simple, robust and reliable design
- VMV's domestic expert team technology, knowledge and service guarantee

Material of main parts

Number	Name	Material
1	Bonnert	SS304
2	Valve core	SS440C
3	Valve body	SS304

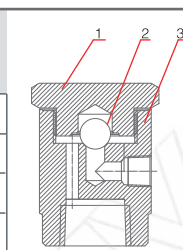

304 material PN25 Body Pressure-Temperature Ratings

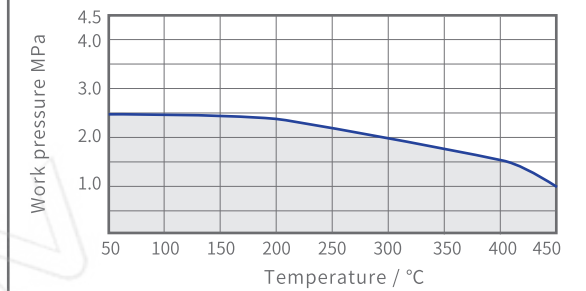

Work scope

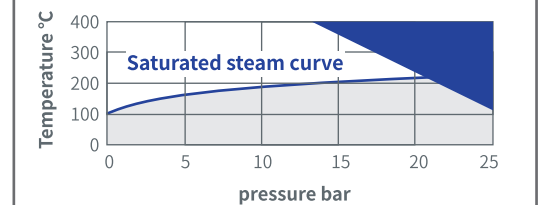

Flow chart

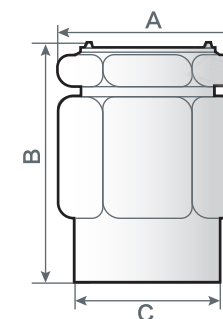
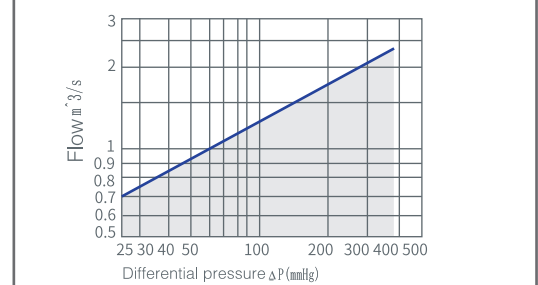

Size Parameters

Model	Connection Method	Nominal Size	Nominal Pressure	External Dimensions mm			Weight Kg
				A	B	C	
VB21	thread	1/2"	PN25	40	54	35	0.38
VB21	thread	3/4"	PN25	52	65	46	0.7

Silencer

Mixer

DF3 Silencer

Mixer IM40M



Product Features

The DF3 silencer is compact and is used to discharge to the steam trap outlet of the inlet condensate return pipeline. It reduces the noise and water hammer problems caused by rapid cooling of flash condensate at the steam trap discharge outlet.

The main body of the silencer is made of SS304, the inner part is stainless steel, and a filter device is installed at the inlet.

- Nominal pressure PN40;
- The maximum allowable temperature is 400°C;
- Maximum working pressure 3.2MPa;
- Maximum operating temperature 325°C
- The connection method is threaded Rc, BSP, NPT

Technical Standard

- GB/T12250-2005 Steam Traps Terminology Marking Structure Length
- GB/T22654-2008 Technical Conditions Steam Traps
- GB/T12251-2005 Test Method Steam Traps
- ISO 6948 Automatic steam traps

Production and performance characteristic tests

Structure Diagram

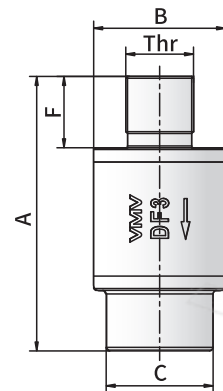

Structural Dimension Table

Product Type	Nominal Size	A	B	C	Thr	f	Weight
DF1	DN15	85	37	30	BSP 1/2"	18	0.3 kg
DF2	DN20	90	39	35	BSP 3/4"	20	0.3 kg
DF3	DN25	95	47	44	BSP 1"	24	0.3 kg

Technical Parameter

Model	Connection Method	Nominal Pressure PN	Working Pressure Range MPa	Temperature°C/ Pressure MPa
DF1	Screw thread	25	0.05-2.5	325/1.6
DF2	Screw thread	25	0.05-2.5	325/1.6
DF3	Screw thread	25	0.05-2.5	325/1.6

Material Table

- Body: Stainless Steel
- Interface: Stainless Steel
- Other Internals: Stainless Steel

304 Material PN25 Valve Body Pressure-Temperature Ratings

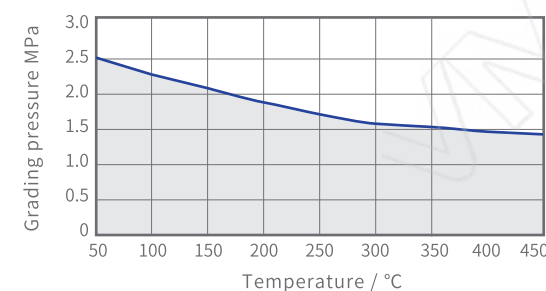

Technical Parameter

Model	Connection Method	Nominal Pressure PN	Working Pressure RangeMPa
IN40M	Threaded	25	0.5-1.7
	Butt welding	25	0.5-1.7

Condition Temperature°C/ PressureMPa	Maximum Heating Temperature°C/
207/1.7	90
207/1.7	90

Inlet pressure and flow

System Pressure bar	Flow Kg/h	System Pressure bar	Flow Kg/h
0.5	222	9	1820
1	400	10	1950
2	580	11	2250
3	805	12	2370
4	970	13	2595
5	1125	14	2710
6	1295	15	2815
7	1445	16	2065
8	1620	17	3200

CF8 Material PN25 Valve Body Pressure-Temperature Ratings

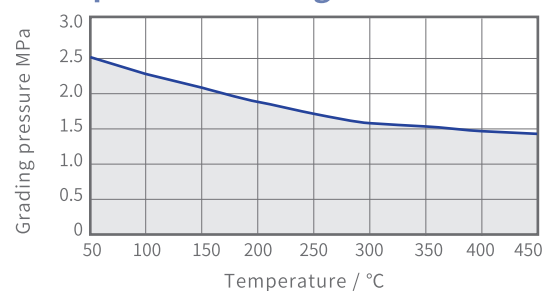

Mixers are used where steam is used to heat water or other fluids. When working, the highspeed jet of steam sucks and mixes the liquid from the annular hole, and then sprays the heated medium into the water tank. The steam and the medium are fully mixed to avoid the temperature stratification difference.

IN40M has external thread and butt welding type. When installing with higher flow rate, two or more injectors can be installed in parallel.

Structural Features

- All stainless steel 304 material
- No moving parts, compact design
- Noise and vibration can be minimized

Installation Notes

- The mixer is installed low in the tank, preferably on the centerline, and injects steam horizontally.
- The piping can be inside or outside the tank.
- Steam piping must be well secured to protection against vibration and stress on tank walls.
- It is recommended to use a suitable adhesive on threaded joints.

Technical Standard

- GB/T12250-2005 Steam Trap Terminology Marking Structure Length
 - GB/T22654-2008 Technical Conditions Steam Traps
 - GB/T12251-2005 Test Method Steam Traps
 - ISO 6948 Automatic steam traps
- Production and performance characteristic tests

Structure Diagram

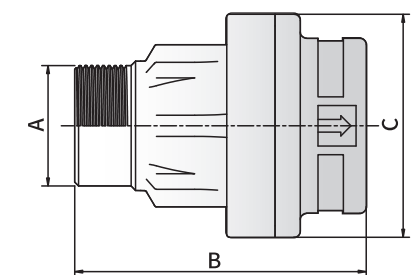

Structural Dimension Table

Model	Nominal Size	A	B	C	Weight
IN40M	DN40	48	115	88	1.6 kg
	DN40	48	115	88	1.6 kg

Newton Steam&Thermal Energy System

Water Separator

IN Single Mixer

Water Separator AS7

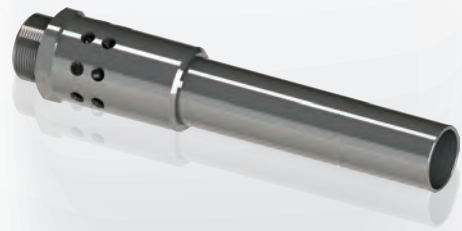

Features

Single mixers are used where steam is used to heat water or other fluids. When working, the highly sprayed steam inhales the liquid from the ring hole, mixes it, and then sprays the heated medium into the water tank. The steam and the medium are fully mixed to avoid the difference in temperature stratification. The single mixer has external thread and butt welding type, and two or more injectors can be installed in parallel when higher flow rates are required.

Structural Features

All stainless steel.
No moving parts, compact design.
Noise and vibration can be minimized.

Occasion Applicable

Boilers feed water heating and deaeration of ideal water application and fluids' efficient steam heating, mixing and circulation.

Installation Precautions

The single mixer is installed at a lower position in the tank, preferably at the center line, spraying steam horizontally.
Pipes can be installed inside or outside the tank. Steam piping must be securely secured against vibration and stress on the tank walls.
It is recommended to use a suitable adhesive for threaded joints.

Valve shell pressure-temperature rating (PN2.5MPa; WCB material)

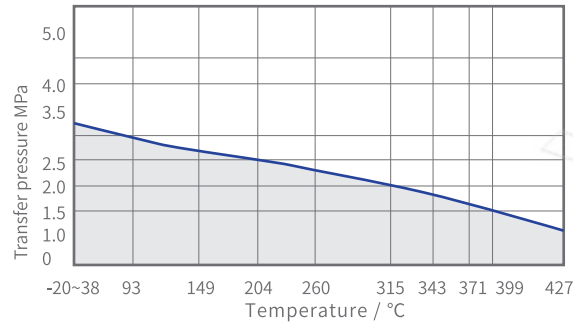

Structure Diagram

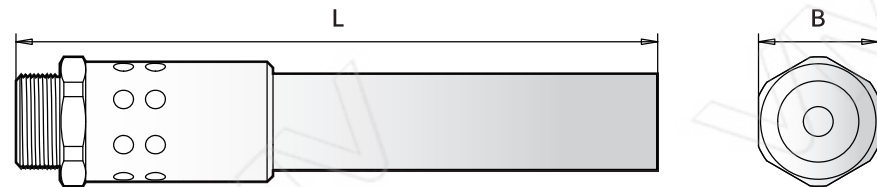

Structural Dimension Table

Model	Connection	DN	PN	Mpa	Temp°C/MPa	L	A	B	Rc	Weight
IN	Thread	IN15	25	0.5-1.7	207/1.7	210	40	36	1/2"	0.5kg
	Thread	IN20	25	0.5-1.7	207/1.7	210	40	36	3/4"	0.5kg
	Thread	IN25	25	0.5-1.7	207/1.7	230	50	44	1"	0.85kg
	Thread	IN32	25	0.5-1.7	207/1.7	270	50	50	1-1/4"	1.7kg
	Thread	IN40	25	0.5-1.7	207/1.7	320	65	60	1-1/2"	2.5kg
			IN50	25	0.5-1.7	207/1.7	360	76	70	2"

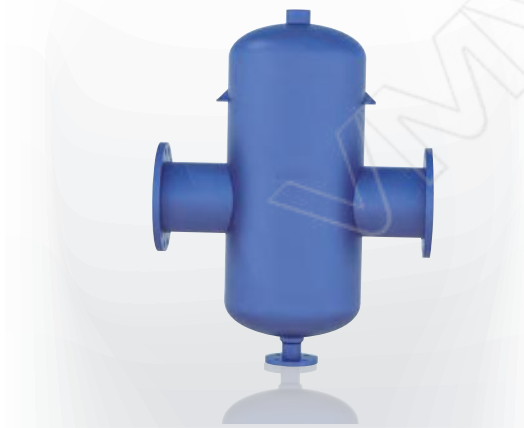

Working Principle

The product is a baffle type separator, which is used to separate steam, compressed air and other droplets contained in gas. It can improve the working performance of the separator when equipped with a thermal insulation jacket. The steam with a large amount of water enters the steam separator and moves in a centrifugal downward slope in it. The entrained water is separated due to the reduced speed. The separated liquid flows into the lower part and is discharged from the body through the steam trap, and the dry and clean steam is discharged from the outlet of the separator.

A105 Pipe Material

Technical Standard

- GB/T12250-2005 Steam Traps Terminology Marking Structure Length
- GB/T22654-2008 Technical Conditions Steam Traps
- GB/T12251-2005 Test Method Steam Traps
- ISO 6948 Automatic steam traps

Production and performance characteristic tests

Technical Parameter

Model	Connection Method	Nominal Pressure DN	Working Pressure Range MPa	Condition Temperature °C/ Pressure MPa
		16	0.05-1.6	260/1.0
		16	0.05-1.6	260/1.0
		16	0.05-1.6	260/1.0
		16	0.05-1.6	260/1.0
		16	0.05-1.6	260/1.0
AS7	Flange	16	0.05-1.6	260/1.0
		16	0.05-1.6	260/1.0
		16	0.05-1.6	260/1.0
		16	0.05-1.6	260/1.0
		16	0.05-1.6	260/1.0
		16	0.05-1.6	260/1.0
		16	0.05-1.6	260/1.0

Structure Diagram

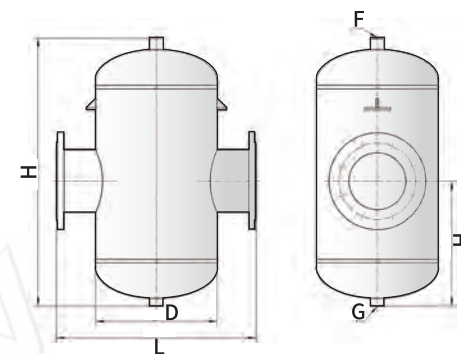

Structural Dimension Table

Model	Nominal Size	L	H	D	E	F	G	Weight	Capacity
AS7	DN15	230	450	108	200	1/2"	1/2"	2.9kg	2.9L
	DN20	230	450	108	200	1/2"	1/2"	3.5kg	3.5L
	DN25	350	500	159	220	1/2"	1/2"	4.8kg	4.8L
	DN32	350	500	159	220	1/2"	1/2"	6.6kg	6.6L
	DN40	360	500	159	220	3/4"	1/2"	8.8kg	8.8L
	DN50	420	638	219	252	1"	3/4"	10.6kg	10.6L
	DN65	420	638	219	252	1"	3/4"	17.5kg	17.5L
	DN80	523	735	273	332	2"	3/4"	20.5kg	20.5L
	DN100	574	795	324	337	2"	3/4"	29kg	29L
	DN125	656	843	356	310	2"	3/4"	43kg	43L
	DN150	706	935	406	347	2"	3/4"	64kg	64L

Work Scope

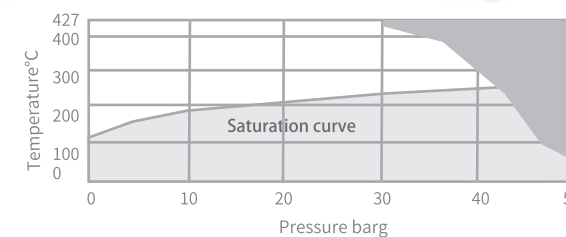

Wafer Check Valve

DIN Strainer

ZM71H-16P Wafer Check Valve

DIN Strainer YG45

Structural Features

MZ71H-16P is a wafer type check valve. The valve seat and valve disc are processed by heat treatment and aging treatment, and the machining accuracy reaches Micron (μm) level, and zero leakage when closed. Suitable for steam pipelines, noncorrosive gases, liquids and other medium

Technical Standard

- GB/T12250-2005 Steam Traps Terminology Marking Structure Length
- GB/T22654-2008 Technical Conditions Steam Traps
- GB/T12251-2005 Test Method Steam Traps
- ISO 6948 Automatic steam traps

Production and performance characteristic tests

Structure Diagram

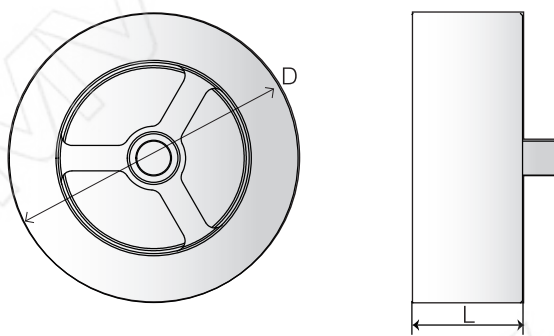

Structural Dimension Table

unit(mm)				
Model	Nominal Size	L	D	Weight
MH71H-25P	DN20	19	55	0.24 kg
	DN25	22	64	0.36 kg
	DN32	28	74	0.55 kg
	DN40	32	84	0.76 kg
	DN50	40	103	1.32 kg
	DN65	46	122	2 kg
	DN80	50	135	2.5 kg

Technical Parameter

Model	Connection Method	Nominal Pressure PN	Working Pressure Range MPa	Condition Temperature $^{\circ}\text{C}$ / Pressure MPa
MH71H-25P	Wafer	25	0.05-2.5	220/2.5
		25	0.05-2.5	220/2.5
		25	0.05-2.5	220/2.5
		25	0.05-2.5	220/2.5
		25	0.05-2.5	220/2.5
		25	0.05-2.5	220/2.5
		25	0.05-2.5	220/2.5

Material Table

Valve body:304 Valve disc:420J2
Valve seat:420J2 Spring:304

(PN40; CF8/304 material) Valve Body Pressure-Temperature Ratings

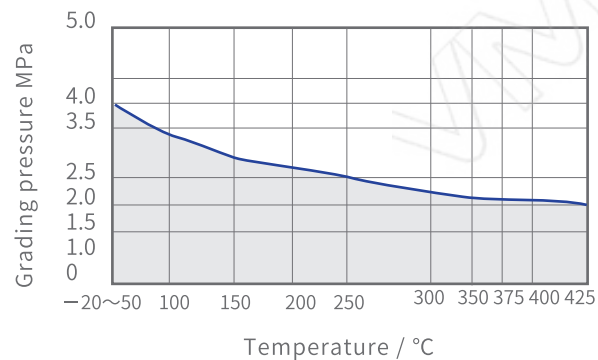

Structural Features

The DIN standard Y type strainer is a device used to eliminate particulate impurities in the medium, which can effectively protect the normal operation of valves and equipment on the pipeline. When cleaning is required, just take out the detachable strainer screen and reload it after processing, which is extremely convenient for maintenance. WCB cast steel material, double layer stainless steel strainer screen has more thorough filtration of impurities and better corrosion resistance. Optional drain plug for quick maintenance.

Technical Standard

- GB/T12250-2005 Steam Trap Terminology Marking Structure Length
- GB/T22654-2008 Technical Conditions Steam Traps
- GB/T12251-2005 Test Method Steam Traps
- ISO 6948 Automatic steam traps

Production and performance characteristic tests

Structure Diagram

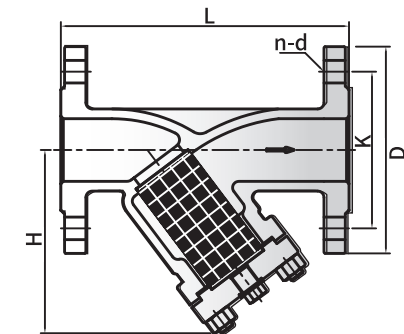

Structural Dimension Table

unit(mm)							
Model	Nominal Size	L	H	D	K	n-d	Weight
YG45	DN15	130	85	95	65	4-14	2.9 kg
	DN20	150	95	105	75	4-14	3.5 kg
	DN25	160	110	115	85	4-14	4.8 kg
	DN32	180	125	140	100	4-18	6.6 kg
	DN40	200	145	150	110	4-18	8.8 kg
	DN50	230	155	165	125	4-18	10.6 kg
	DN65	290	175	185	145	4-18	17.5 kg
	DN80	310	210	200	160	8-18	20.5 kg
	DN100	350	230	220	190	8-18	29 kg
	DN125	400	270	250	220	8-18	43 kg
	DN150	480	300	285	250	8-22	64 kg

Technical Parameter

Model	Connection Method	Nominal Pressure DN	Working Pressure Range MPa	Condition Temperature $^{\circ}\text{C}$ / Pressure MPa
YG45	Flange	15	0.05-1.6	260/1.0
		20	0.05-1.6	260/1.0
		25	0.05-1.6	260/1.0
		32	0.05-1.6	260/1.0
		40	0.05-1.6	260/1.0
		50	0.05-1.6	260/1.0
		65	0.05-1.6	260/1.0
		80	0.05-1.6	260/1.0
		125	0.05-1.6	260/1.0
		150	0.05-1.6	260/1.0

Work Scope

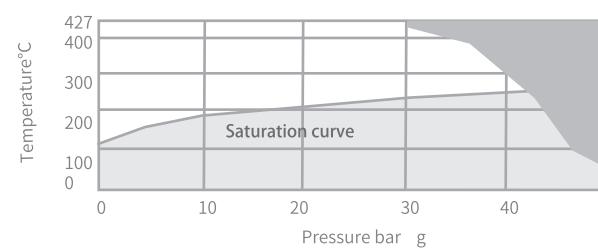

Sight Glass

S1 Sight Glass

Overview

Single window sight glass, threaded connection, available in different sizes in bronze and brass products.

Structural Features

1. The structure is compact, saving installation space to the greatest extent and meeting customer needs.
2. Provide customized threaded connections (BSP or NPT) to meet the individual needs of customers.
3. Temperature resistant calcified glass lens with explosion proof function.
4. Flexible graphite gasket with high sealing and erosion resistance.

Applicable Scope

It is used for the flow and reaction of liquid, gas, steam and other media in the pipelines of petroleum, chemical, pharmaceutical, food and other industrial production equipment, and plays a role in monitoring production and avoiding accidents in the production process.

Warning

Condensate water in some applications can dissolve the sight glass, especially if the water contains corrosive alkaline and acidic substances. Therefore, it is recommended to check the sight glass regularly and replace the glass immediately if it becomes thinner. When viewing, wear goggles to protect your eyes.

Data Sheet

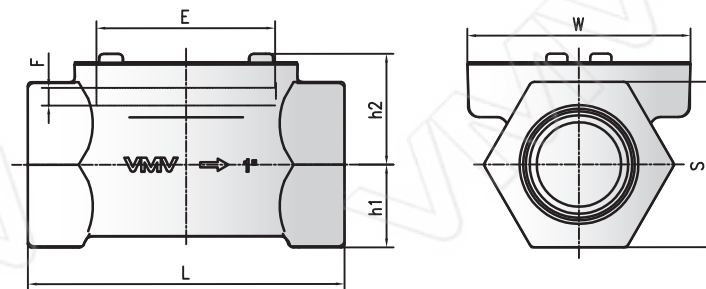

Structural Dimension Table

Model	Nominal Size	L	W	S	h1	h2	E	F	Weight
S1	DN10	89	63	31	16	29	51	5	0.55Kg
	DN15	89	63	31	16	29	51	5	0.55Kg
	DN20	89	63	37	19	32	51	5	0.65Kg
	DN25	90	63	47	24	33	51	5	0.8Kg

Technical Parameter

Model	Connection Method	Nominal Pressure DN	Working Pressure RangeMPa	Condition Temperature°C/ Pressure MPa
S1	Screw thread	5	0.05-0.35	148/0.35
	Screw thread	5	0.05-0.35	148/0.35
	Screw thread	5	0.05-0.35	148/0.35
	Screw thread	5	0.05-0.35	148/0.35

Material Table

- Body: bronze, brass
- Gasket: Flexible Graphite
- Sight Window: high temperature quartz glass
- Bonnet: Bronze, Brass

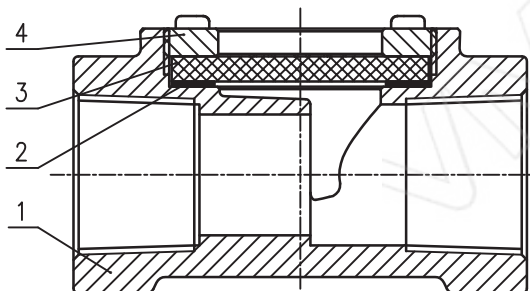

Condensate recovery system and steam energy-saving products

Condensate flash recovery system

Condensate flash system



P1	Primary steam pressure	bar	P	Power steam pressure	bar
P2	Flash steam pressure	bar	Pb	Back pressure	bar
Q1	Saturated condensate flow rate	kg/h			

Steam Ejector



Parameters that users need to provide

Noun	Definition	单位
Pp	Absolute pressure of working steam	Pa
tp	Temperature of working steam	°C
Vp	Specific volume of working steam	M ³ /kg
ip	Specific enthalpy of working steam	kJ/kg
PH	Absolute pressure of injected steam	Pa
TH	Temperature of injected steam	°C
VH	Specific volume of injected steam	M ³ /kg
iH	Specific enthalpy of injected steam	kJ/kg
GH	Flow rate of injected steam	kg/h
PC	Pressure after steam compression	Pa

Tube heat exchanger



Parameters that users need to provide

S	Heat Exchange Area	m ²	Q2	Secondary medium flow rate	kg/h
	Primary medium			Secondary medium	
Ps	Primary pressure	bar	T21	Initial temperature of secondary medium	°C
T1	Primary temperature	°C	T22	Secondary medium outlet temperature	°C
DN	Primary nominal diameter	DN		Secondary nominal diameter	

Basic configuration of steam system unit

Sub Cylinder drain system

Steam Pipeline Conveying Pipeline Drainage System



Picture 001



Picture 002

Equipment Drainage System Unit Configuration



Picture 005

Steam Water Separation Device

Condensate Recovery Device

Steam Heat Pressure Reducing System



Picture 003



Picture 006



Picture 007

Steam Temperature Reduction and Pressure Reduction Device



Picture 004

Steam Tracing System

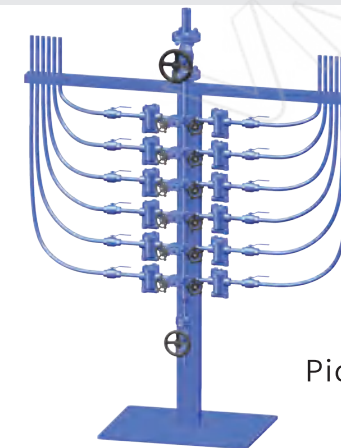

Picture 008

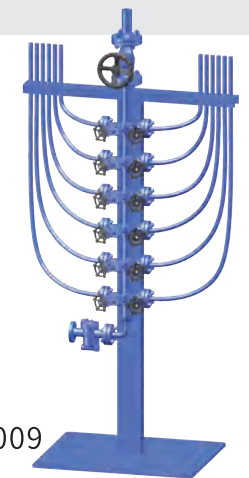

Picture 009

Hot Air Unit Control and Drainage System

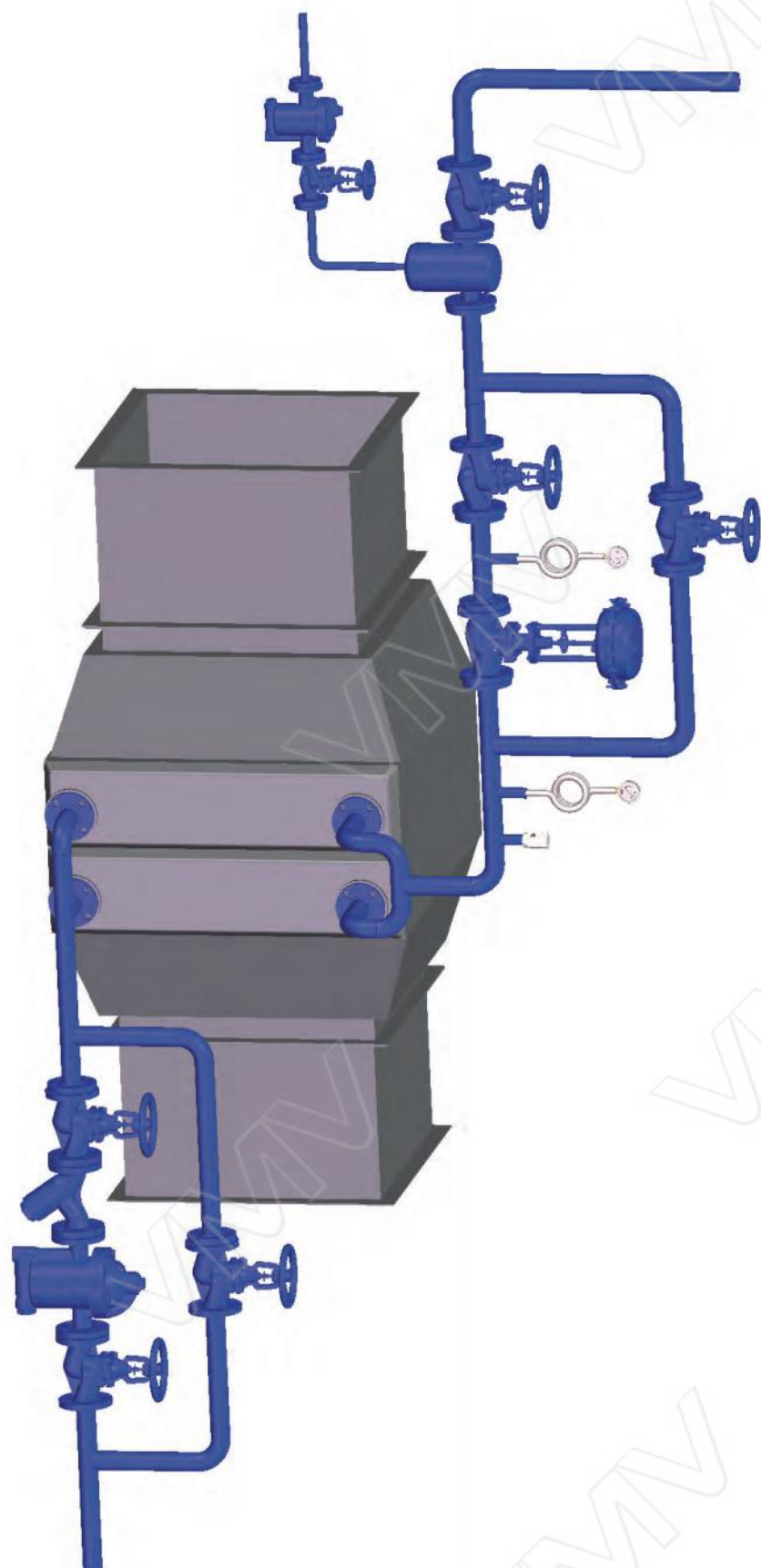

Hot air unit control and drainage system

Steam System Piping and Equipment Process Piping

Piping of Steam Delivery Main and Branch Pipes



Picture 010

Piping of the Condensate Main and Branch Pipes

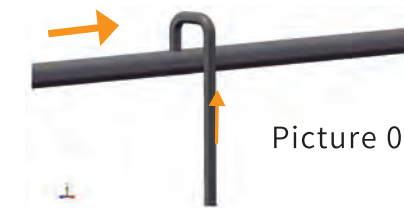

Picture 011

Drainage at the End of the Main Steam Pipeline



Picture 012



Error X

Picture 013

Drainage at the Low Point of the Main Steam Pipeline

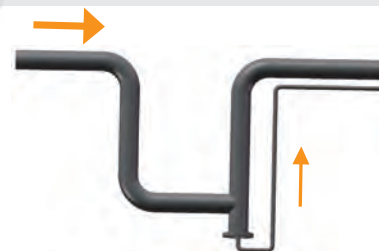

Picture 014

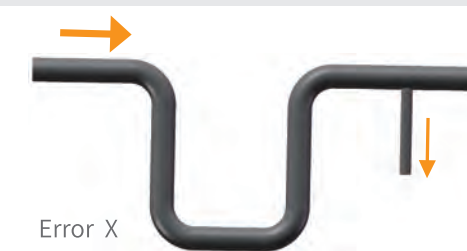

Error X

Picture 015

Several Common Equipment Hydrophobic Systems

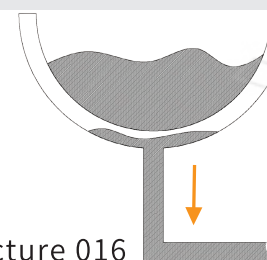

Picture 016



Picture 017

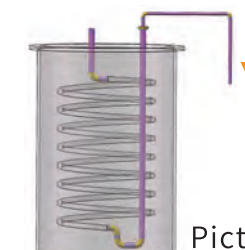

Picture 018

Common equipment low point hydrophobic
Recommended:
Mechanical steam traps

Dryer (Rotary) Siphon Drainage
Preferred:
Lever float proportional regulating steam trap

Melting tank siphon hydrophobic
Preferred:
Lever float proportional regulating steam trap